



**NON-RETURN DAMPER,
VARIANT ARK**

Non-return damper with
linkage

ER – SELF-POWERED DAMPERS

FOR THE FAST AND SIMPLE INSTALLATION OF NON-RETURN DAMPERS AND PRESSURE-RELIEF DAMPERS

Installation subframe for the fast and precise installation of non-return dampers and pressure-relief dampers. Installation subframes with fixing tabs are mortared into the wall opening, then the dampers are fastened to the subframes

- Angle sections made of galvanised steel or stainless steel
- Galvanised steel variant with screw-on fixing tabs
- Stainless steel variant with welded fixing tabs

Application



Application

- For the installation of non-return dampers and pressure-relief dampers in walls and ceiling slabs
- Simplified installation
- The installation subframe allows for the fast, simple and precise installation of non-return dampers and pressure-relief dampers

Nominal sizes

- B: 200, 400, 600, 800, 1000, 1200 mm (intermediate sizes: 201 – 1199 mm, in increments of 1 mm)
- H: 345, 675, 1005, 1335, 1665, 1995 mm (intermediate sizes 355 – 505, 685 – 835, 1015 – 1165, 1345 – 1495, 1675 – 1825 mm in increments of 1 mm)
- Any combination of B × H

Description



Parts and characteristics

- Installation subframe consisting of angle sections
- Threaded studs or hexagon head screws
- Washers
- Hexagon nuts
- Fixing tab

Materials and surfaces

UL-1, UL-2

- Installation subframe made of galvanised steel (angle section 35 × 35 × 3 mm)
- Welded fixing tabs with integral nuts, screws and washers made of galvanised steel

KUL, ARK, ARK2

- Installation subframe made of galvanised steel (angle section 35 × 35 × 3 mm)
- Screw-on fixing tabs, threaded studs, screws, nuts and washers made of galvanised steel

ARK-A2, ARK2-A2

- Installation subframe made of stainless steel, material no. 1.4301
- Welded fixing tabs, threaded studs, nuts and washers made of stainless steel, material no. 1.4301

TECHNICAL INFORMATION

Function



Installation subframe made of galvanised steel for non-return dampers and pressure-relief dampers

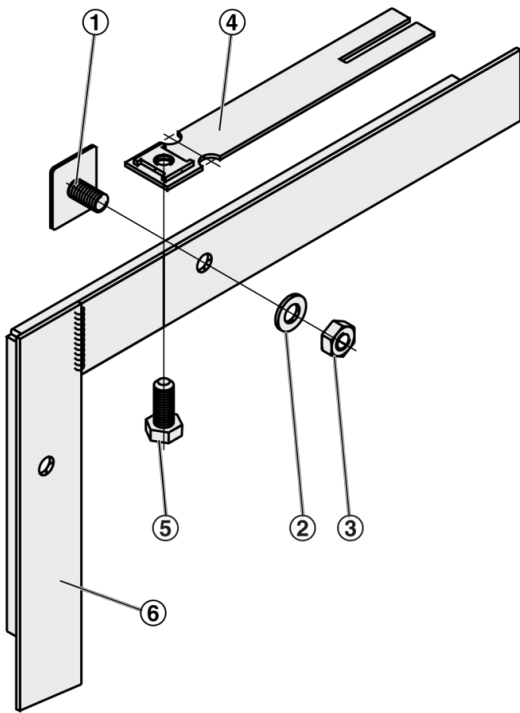

- ① Threaded stud
- ② Washer
- ③ Hexagon nut
- ④ Fixing tab
- ⑤ Hexagon head screw
- ⑥ Installation subframe

Installation subframe for non-return dampers and pressure-relief dampers

Description	Type
Galvanised steel	UL, KUL, ARK, ARK2
Stainless steel	ARK-A2, ARK2-A2

Materials

Part	Damper type or variant	Material	Notes
Installation subframe	UL, KUL, ARK, ARK2	Galvanised steel	Angle section frame 35 x 35 x 3 mm
	ARK-A2, ARK2-A2	Stainless steel, material no. 1.4301	
Fixing tabs, screws, nuts and washers	UL	Galvanised steel	Welded fixing tabs
	KUL, ARK, ARK2	Galvanised steel	Screw-on fixing tabs
Fixing tabs, threaded stubs, nuts and washers	ARK-A2, ARK2-A2	Stainless steel, material no. 1.4301	Welded fixing tabs

Installation subframe ready to be mortared in

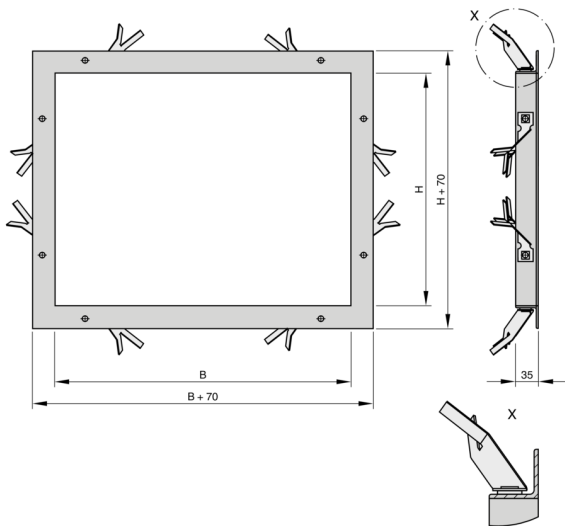

Before the subframe is mortared in, the fixing tabs must be bent and spread (by others).

Installation and commissioning

UL

Before mortaring in the installation subframe

- Bend and spread the fixing tabs

After mortaring in the installation subframe

- Align the non-return damper with the subframe and fasten it

KUL, ARK, ARK2

Before mortaring in the installation subframe

- Fasten the threaded studs, washers and nuts to the installation subframe
- Fix the screw-on fixing tabs with hexagon nuts
- Fasten the remaining screw-on fixing tabs (regular spacing, about every 375 - 625 mm)

After mortaring in the installation subframe

- Unscrew the hexagon nuts
- Align the non-return damper or pressure-relief damper with the subframe and fasten it

Installation in front of internal wall openings

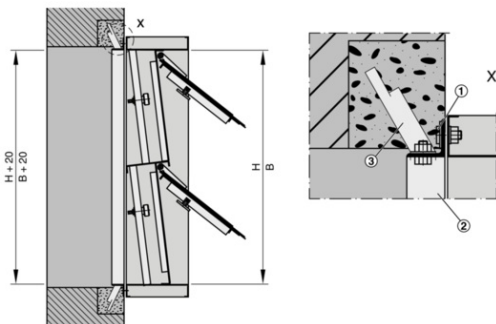

- ① Threaded stud
- ② Installation subframe
- ③ Fixing tab

Illustration shows ARK2