

Induction units for suspended ceilings

Type DID632

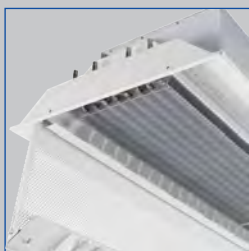

DID632, hinged induced air grille

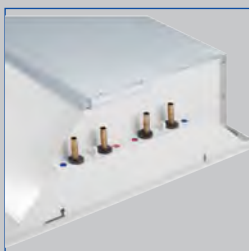

DID632, water connections



Eurovent certification



Tested to VDI 6022



Active chilled beam with two-way air discharge and horizontal heat exchanger, suitable for grid ceilings with grid size 600 or 625

Active chilled beam for heating and cooling, with 2-pipe or 4-pipe heat exchanger, for integration with various ceiling systems

- Preferably for room heights up to 4.0 m
- High heating and cooling capacity with a low conditioned primary air volume flow rate and low sound power level
- Four nozzle variants to optimise induction based on demand
- Hinged, removable induced air grille in four designs

Optional equipment and accessories

- Control system
- Additional casing for extract air
- Heat exchanger powder-coated black
- Powder coating in many different colours, e.g. RAL CLASSIC
- Adjustable air control blades for air direction control
- With an extended border also suitable for freely suspended installation

Type		Page
DID632	General information	DID632 – 2
	Function	DID632 – 4
	Technical data	DID632 – 6
	Quick sizing	DID632 – 7
	Specification text	DID632 – 11
	Order code	DID632 – 12
	Variants	DID632 – 14
	Attachments	DID632 – 15
	Dimensions and weight	DID632 – 16
	Installation examples	DID632 – 22
	Installation details	DID632 – 23
	Basic information and nomenclature	DID632 – 24

Application

Application

- Active chilled beams of Type DID632 for the integration into various ceiling systems, preferably for room heights up to 4.0 m
- Particularly suitable for grid ceilings with grid size 600 or 625
- Adjustable air control blades (optional) allow for the manual adjustment of the air discharge direction
- 2-pipe or 4-pipe heat exchangers enable good comfort levels with a low conditioned primary air volume flow rate
- Energy-efficient solution since water is used for heating and cooling
- Adjustable air control blades for air direction control
- Hinged, removable induced air grille in four designs
- Horizontal heat exchanger as 2-pipe or 4-pipe system
- Internal nozzle plate with punched nozzles (non-combustible)
- Water connections at the narrow side, Ø12 mm Cu pipe, either with plain tails or with G½" external thread and flat seal

Nominal sizes

- 900, 1200, 1500, 1800, 2100, 2400, 2700, 3000 mm

Special characteristics

Description

Variants

- DID632-LR: With induced air grille – perforated sheet metal, circular holes
- DID632-LQ: With induced air grille – perforated sheet metal, square holes
- DID632-GL: With induced air grille – longitudinal blades
- DID632-GQ: With induced air grille – transverse blades

Heat exchanger

- 2: 2-pipe systems
- 4: 4-pipe systems

Nozzle variants

- Z: Small plus
- M: Medium

- G: Large
- U: Extra large

Construction

- Powder-coated RAL 9010, pure white, gloss level 50 %
- P1: Powder-coated in any other RAL colour, gloss level 70 %
- P1: Powder-coated RAL 9006, white aluminium, gloss level 30 %

Attachments

- Additional casing with extract air spigot (45° connection)
- Water connection A1: G½" external thread and flat seal
- Water connection A2: G½" union nut and flat

- seal
- Adjustable air control blades for air direction control

Useful additions

- Connecting hoses
- Control equipment consisting of a control panel including a controller with integral room temperature sensor; valves and valve actuators; and lockshields
- X-AIRCONTROL control system

Construction features

- Spigot is suitable for circular ducts to EN 1506 or EN 13180
- Four suspension points for on-site installation (by others)
- Four nozzle variants to optimise induction based on demand
- Optional additional casing with extract air spigot (45° connection)
- Optional adjustable air control blades for air direction control (retrofit at a later stage is not possible)

Materials and surfaces

- Casing, front frame, nozzle plate, and perforated induced air grille (LR/LQ) made of galvanised sheet steel

- Blades of the induced air grille (GL/GQ) made of aluminium sections
- Heat exchanger with copper tubes and aluminium fins
- Exposed surfaces are powder-coated pure white (RAL 9010) or in any other RAL colour
- Heat exchanger also in black (RAL 9005)
- Additional casing with extract air spigot made of galvanised sheet steel
- Air control blades made of polypropylene, UL 94, flame retardant (V0)

Standards and guidelines

- Products are certified by Eurovent (no. 09.12.432) and listed on the Eurovent website
- Declaration of hygiene conformity to VDI 6022

Maintenance

- No moving parts, hence low maintenance
- The heat exchanger can be vacuumed with an industrial vacuum cleaner if necessary
- VDI 6022, Part 1, applies (Hygiene requirements for ventilation and air-conditioning systems and units)

Functional description

Active chilled beams provide centrally conditioned primary air (fresh air to the room and use heat exchangers for additional cooling and/or heating. The primary air is discharged through nozzles (in 4 sizes) into the mixing chambers; as a result of this, secondary air is induced. Secondary air

(room air) is induced via the induced air grille and passes through the horizontal heat exchanger, where it is heated or cooled. Primary and secondary air mix and are then supplied to the room horizontally through the supply air slots.

Schematic illustration of DID632

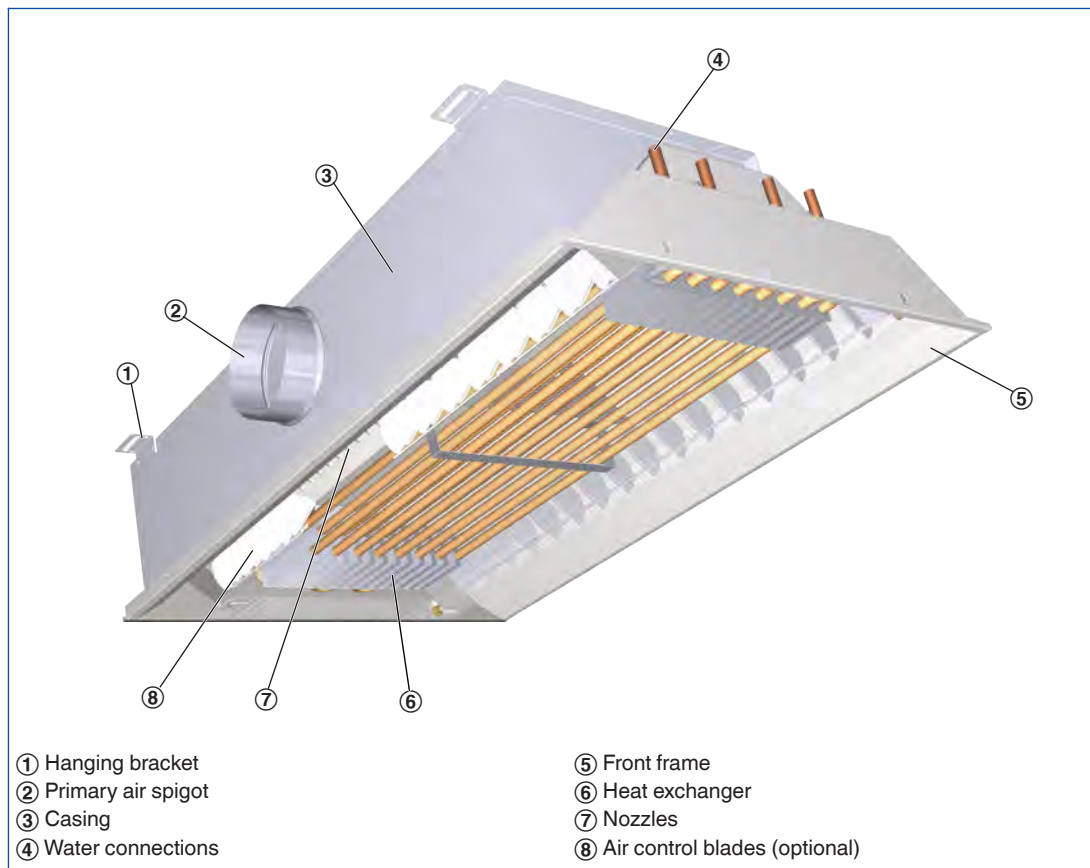

Principle of operation – DID632

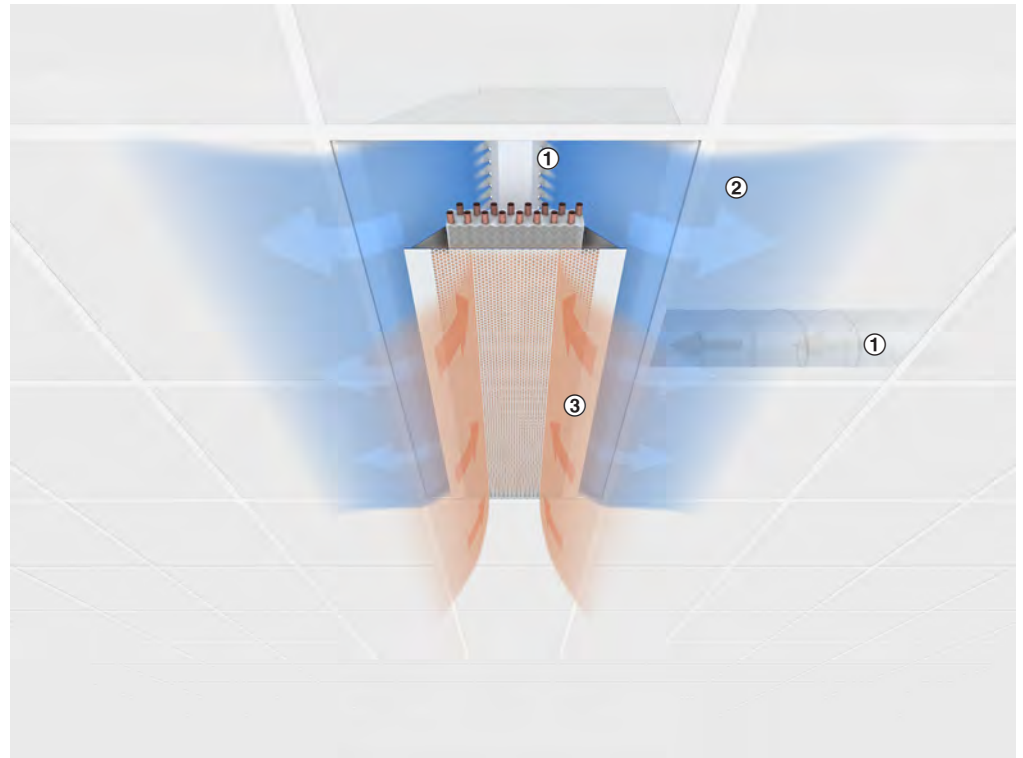

- ① Conditioned fresh air (primary air)
- ② Supply air

- ③ Room air (secondary air)

Nominal length	900, 1200, 1500, 1800, 2100, 2400, 2700, 3000 mm
Length	893 – 3000 mm
Height	210 mm
Width	593, 598, 618, 623 mm
Primary air spigot, diameter	123/158 mm
Primary air volume flow rate	6 – 85 l/s or 22 – 306 m ³ /h
Cooling capacity	Up to 2450 W
Heating capacity	Up to 2970 W
Max. operating pressure, water side	6 bar
Max. operating temperature	75 °C

The quick sizing table contains operating points for defined reference units. For other operating points you may use the Easy Product Finder design software.

Quick sizing

L _N	①	Primary air		②	③	Cooling mode				Heating mode		
		V̇ _{Pr} l/s	V̇ _{Pr} m ³ /h	Δp _t Pa	L _{WA} dB(A)	2-pipe and 4-pipe systems				4-pipe system		
						Q _{tot} W	Q _{WK} W	Δt _w K	Δp _w kPa	Q _{WH} = Q _{tot} W	Δt _w K	Δp _w kPa
900	Z	6	22	67	<20	411	339	2.6	2.4	495	8.5	0.2
		9	32	151	<20	573	464	3.6	2.4	673	11.6	0.2
		12	43	268	22	690	545	4.3	2.4	786	13.5	0.2
	M	9	32	65	<20	459	350	2.7	2.4	512	8.8	0.2
		13	47	136	<20	628	472	3.7	2.4	683	11.7	0.2
		18	65	260	28	785	568	4.4	2.4	818	14.1	0.2
	G	16	58	58	<20	590	397	3.1	2.4	577	9.9	0.2
		24	86	129	29	815	526	4.1	2.4	759	13.1	0.2
		34	122	259	38	1035	625	4.9	2.4	897	15.4	0.2
	U	30	108	65	30	847	485	3.8	2.4	702	12.1	0.2
		36	130	94	35	964	530	4.1	2.4	764	13.1	0.2
		44	158	140	40	1107	577	4.5	2.4	829	14.3	0.2
1200	Z	8	29	64	<20	529	433	3.4	3.1	628	10.8	0.3
		12	43	145	<20	728	584	4.6	3.1	839	14.4	0.3
		16	58	257	26	871	679	5.3	3.1	970	16.7	0.3
	M	12	43	63	<20	592	447	3.5	3.1	648	11.2	0.3
		17	61	126	23	790	585	4.6	3.1	841	14.5	0.3
		24	86	250	32	995	705	5.5	3.1	1006	17.3	0.3
	G	21	76	59	22	750	496	3.9	3.1	718	12.3	0.3
		32	115	126	34	1042	656	5.1	3.1	939	16.2	0.3
		44	158	238	42	1292	762	6.0	3.1	1083	18.6	0.3
	U	36	130	54	33	1011	577	4.5	3.1	830	14.3	0.3
		42	151	73	37	1129	623	4.9	3.1	893	15.4	0.3
		48	173	95	41	1240	661	5.2	3.1	945	16.3	0.3
1500	Z	10	36	63	<20	639	519	4.1	3.7	749	12.9	0.3
		15	54	141	21	871	690	5.4	3.7	986	17.0	0.3
		20	72	251	29	1037	795	6.2	3.7	1128	19.4	0.3
	M	15	54	62	<20	716	535	4.2	3.7	772	13.3	0.3
		20	72	109	25	908	666	5.2	3.7	953	16.4	0.3
		30	108	243	36	1187	825	6.4	3.7	1168	20.1	0.3
	G	30	108	71	30	1014	652	5.1	3.7	934	16.1	0.3
		38	137	114	36	1209	751	5.9	3.7	1068	18.4	0.3
		44	158	153	40	1338	807	6.3	3.7	1144	19.7	0.3
	U	42	151	49	37	1166	659	5.2	3.7	943	16.2	0.3
		46	166	59	40	1245	691	5.4	3.7	986	17.0	0.3
		50	180	70	42	1321	718	5.6	3.7	1024	17.6	0.3

¹ If the air discharge is not straight, the water-side capacity will be slightly affected; blades set at 45° may cause a loss of up to 5 %.

① Nozzle variant

② Pressure drop

③ Air-regenerated noise

Reference values

Parameter	Cooling	Heating
t _R	26 °C	22 °C
t _{Pr}	16 °C	22 °C (isothermal)
t _{wv}	16 °C	50 °C
V̇ _w (L _N 900 – 1800 mm)	110 l/h	50 l/h
V̇ _w (L _N from 2100 mm)	200 l/h	110 l/h

Quick sizing

L _N	①	Primary air		②	③	Cooling mode				Heating mode		
		\dot{V}_{Pr}	\dot{V}_{Pr}	Δp_t	L _{WA}	2-pipe and 4-pipe systems				4-pipe system		
		l/s	m ³ /h	Pa	dB(A)	Q _{tot}	Q _{WK}	Δt_w	Δp_w	Q _{WH} = Q _{tot}	Δt_w	Δp_w
						W		K	kPa	W	K	kPa
1800	Z	12	43	62	<20	743	598	4.7	4.3	859	14.8	0.3
		18	65	139	24	1003	786	6.1	4.3	1115	19.2	0.3
		24	86	247	32	1188	899	7.0	4.3	1266	21.8	0.3
	M	18	65	61	<20	834	617	4.8	4.3	884	15.2	0.3
		24	86	108	28	1050	760	5.9	4.3	1080	18.6	0.3
		36	130	243	39	1364	930	7.3	4.3	1307	22.5	0.3
	G	30	108	50	29	1015	653	5.1	4.3	935	16.1	0.3
		40	144	89	37	1276	794	6.2	4.3	1126	19.4	0.3
		44	158	107	39	1367	836	6.5	4.3	1182	20.3	0.3
U	40	144	33	37	1143	661	5.2	4.3	945	16.3	0.3	
	44	158	40	40	1230	700	5.5	4.3	998	17.2	0.3	
	50	180	52	43	1352	749	5.9	4.3	1066	18.3	0.3	
2100	Z	14	50	61	<20	994	825	3.5	14.2	1506	11.8	1.6
		21	76	137	22	1363	1110	4.8	14.2	1997	15.6	1.6
		28	101	243	30	1625	1287	5.5	14.2	2297	18.0	1.6
	M	21	76	59	<20	1106	852	3.7	14.2	1553	12.1	1.6
		28	101	105	25	1408	1070	4.6	14.2	1929	15.1	1.6
		42	151	237	36	1844	1337	5.8	14.2	2381	18.6	1.6
	G	36	130	50	26	1364	930	4.0	14.2	1688	13.2	1.6
		56	202	120	38	1921	1246	5.4	14.2	2228	17.4	1.6
		70	252	188	44	2230	1386	6.0	14.2	2462	19.2	1.6
U	60	216	47	37	1793	1070	4.6	14.2	1929	15.1	1.6	
	70	252	64	41	2001	1157	5.0	14.2	2077	16.2	1.6	
	80	288	84	45	2193	1229	5.3	14.2	2199	17.2	1.6	
2400	Z	16	58	61	<20	1113	920	4.0	15.9	1671	13.1	1.8
		24	86	136	24	1516	1226	5.3	15.9	2195	17.2	1.8
		32	115	241	32	1801	1415	6.1	15.9	2510	19.6	1.8
	M	24	86	59	<20	1239	949	4.1	15.9	1722	13.5	1.8
		32	115	105	27	1570	1184	5.1	15.9	2123	16.6	1.8
		48	173	236	38	2047	1468	6.3	15.9	2598	20.3	1.8
	G	40	144	48	28	1491	1009	4.3	15.9	1825	14.3	1.8
		60	216	107	39	2049	1326	5.7	15.9	2362	18.5	1.8
		70	252	145	43	2276	1432	6.2	15.9	2539	19.9	1.8
U	60	216	38	37	1823	1099	4.7	15.9	1979	15.5	1.8	
	70	252	51	41	2040	1196	5.1	15.9	2144	16.8	1.8	
	80	288	67	45	2241	1277	5.5	15.9	2279	17.8	1.8	

¹ If the air discharge is not straight, the water-side capacity will be slightly affected; blades set at 45° may cause a loss of up to 5 %.

① Nozzle variant

② Pressure drop

③ Air-regenerated noise

Reference values

Parameter	Cooling	Heating
t _R	26 °C	22 °C
t _{Pr}	16 °C	22 °C (isothermal)
t _{WV}	16 °C	50 °C
\dot{V}_w (L _N 900 – 1800 mm)	110 l/h	50 l/h
\dot{V}_w (L _N from 2100 mm)	200 l/h	110 l/h

Quick sizing

L _N	①	Primary air		②	③	Cooling mode				Heating mode		
		\dot{V}_{Pr}	\dot{V}_{Pr}	Δp_t	L _{WA}	2-pipe and 4-pipe systems				4-pipe system		4-pipe system
						Q _{tot}	Q _{WK}	Δt_w	Δp_w	Q _{WH} = Q _{tot}	Δt_w	Δp_w
		l/s	m ³ /h	Pa	dB(A)	W				K	W	K
2700	Z	18	65	60	<20	1227	1010	4.3	17.7	1826	14.3	2.0
		27	97	135	26	1661	1336	5.7	17.7	2378	18.6	2.0
		36	130	240	34	1968	1534	6.6	17.7	2706	21.2	2.0
	M	27	97	59	22	1367	1041	4.5	17.7	1880	14.7	2.0
		36	130	105	30	1725	1291	5.6	17.7	2303	18.0	2.0
		54	194	235	40	2240	1589	6.8	17.7	2796	21.9	2.0
	G	45	162	48	29	1648	1105	4.8	17.7	1989	15.6	2.0
		60	216	85	38	2073	1350	5.8	17.7	2402	18.8	2.0
		70	252	116	42	2311	1467	6.3	17.7	2597	20.3	2.0
	U	62	223	33	38	1889	1141	4.9	17.7	2051	16.0	2.0
		73	263	46	43	2134	1254	5.4	17.7	2242	17.5	2.0
		84	302	61	46	2358	1345	5.8	17.7	2395	18.7	2.0
3000	Z	20	72	60	<20	1337	1096	4.7	19.4	1973	15.4	2.1
		30	108	135	28	1800	1438	6.2	19.4	2549	19.9	2.1
		40	144	239	36	2126	1644	7.1	19.4	2885	22.6	2.1
	M	30	108	59	23	1491	1129	4.9	19.4	2030	15.9	2.1
		40	144	105	31	1874	1391	6.0	19.4	2471	19.3	2.1
		60	216	235	42	2424	1701	7.3	19.4	2977	23.3	2.1
	G	50	180	49	32	1799	1196	5.1	19.4	2144	16.8	2.1
		65	234	82	39	2216	1432	6.2	19.4	2538	19.8	2.1
		75	270	109	43	2451	1547	6.7	19.4	2728	21.3	2.1
	U	65	234	31	40	1974	1190	5.1	19.4	2134	16.7	2.1
		75	270	41	44	2202	1297	5.6	19.4	2314	18.1	2.1
		85	306	53	47	2410	1385	6.0	19.4	2461	19.2	2.1

¹ If the air discharge is not straight, the water-side capacity will be slightly affected; blades set at 45° may cause a loss of up to 5 %.

① Nozzle variant

② Pressure drop

③ Air-regenerated noise

Reference values

Parameter	Cooling	Heating
t _R	26 °C	22 °C
t _{Pr}	16 °C	22 °C (isothermal)
t _{wv}	16 °C	50 °C
\dot{V}_w (L _N 900 – 1800 mm)	110 l/h	50 l/h
\dot{V}_w (L _N from 2100 mm)	200 l/h	110 l/h

Aerodynamic data – extract air		Aerodynamic data – extract air		
\dot{V}_{Ext}	\dot{V}_{Ext}	Δp_t	L_{WA}	
l/s	m ³ /h	Pa	dB(A)	
12	43	0.5	<15	
18	65	1.0	<15	
24	86	1.9	<15	
30	108	2.9	<15	
35	126	3.9	<15	
40	144	5.1	<15	
50	180	8.0	20	
60	216	11.6	26	
70	252	15.7	30	
80	288	20.6	34	

This specification text describes the general properties of the product. Texts for variants can be generated with our Easy Product Finder design programme.

Description

Active chilled beams of Type DID632, with two-way air discharge and high thermal output, providing high thermal comfort levels. For installation flush with the ceiling, preferably in rooms with a height up to 4.0 m. The units consist of a casing with suspension points, a spigot, non-combustible nozzles, and a horizontal heat exchanger. Nozzles in four sizes to optimise induction based on demand.

Special characteristics

- Adjustable air control blades for air direction control
- Hinged, removable induced air grille in four designs
- Horizontal heat exchanger as 2-pipe or 4-pipe system
- Internal nozzle plate with punched nozzles (non-combustible)
- Water connections at the narrow side, Ø12 mm Cu pipe, either with plain tails or with G½" external thread and flat seal

Materials and surfaces

- Casing, front frame, nozzle plate, and perforated induced air grille (LR/LQ) made of galvanised sheet steel
- Blades of the induced air grille (GL/GQ) made of aluminium sections
- Heat exchanger with copper tubes and aluminium fins
- Exposed surfaces are powder-coated pure white (RAL 9010) or in any other RAL colour
- Heat exchanger also in black (RAL 9005)
- Additional casing with extract air spigot made of galvanised sheet steel
- Air control blades made of polypropylene, UL 94, flame retardant (V0)

Construction

- Powder-coated RAL 9010, pure white, gloss level 50 %
- P1: Powder-coated in any other RAL colour, gloss level 70 %
- P1: Powder-coated RAL 9006, white aluminium, gloss level 30 %

Technical data

- Nominal length: 900, 1200, 1500, 1800, 2100, 2400, 2700, 3000 mm
- Length: 893 – 3000 mm
- Height: 210 mm
- Width: 593, 598, 618, 623 mm
- Primary air spigot, diameter: 123/158 mm
- Primary air volume flow rate: 6 – 85 l/s or 22 – 306 m³/h
- Cooling capacity: up to 2450 W
- Heating capacity: up to 2970 W
- Max. operating pressure: 6 bar
- Max. operating temperature: 75 °C

Sizing data

Primary air

- \dot{V} _____
[m³/h]
- Δp_i _____
[Pa]

Air-regenerated noise

- L_{WA} _____
[dB(A)]

Cooling

- \dot{Q}_{ges} _____
[W]

Heating

- \dot{Q}_{ges} _____
[W]

DID632

DID632 – LR – 2 – M – LL – AV – A1 / 1800 × 1500 × 593 / P1 – RAL... / G3 / LE / VS												
1	2	3	4	5	6	7	8	9	10	11	12	13

1 Type

DID632 Active chilled beam

2 Induced air grille

GL Longitudinal blades
GQ Transverse blades
LR Perforated metal, circular holes
LQ Perforated metal, square holes

3 Heat exchanger

2 2-pipe
4 4-pipe

4 Nozzle variant

Z Small plus
M Medium
G Large
U Extra large

5 Arrangement of casings and connections

LL (also available as supply and extract air combination)

LR
ML
MR
RL
RR (also available as supply and extract air combination)

Note

L = left side, R = right side, M = centre

6 Additional casing with extract air spigot

No entry: none

AV Front
AH Rear

Available from L = L_N + 250 mm

7 Water connections

No entry: Ø12 mm pipe with plain tails

A1 With G½" external thread and flat seal
A2 With G½" union nut and flat seal

8 Total length (diffuser face) × nominal size [mm]

L × L_N
 Supply air

893 – 1500 × 900
1193 – 1800 × 1200
1493 – 2100 × 1500
1793 – 2400 × 1800
2093 – 2700 × 2100
2393 – 3000 × 2400
2693 – 3000 × 2700
2993 – 3000 × 3000

L is up to 7 mm shorter than L_N

Supply and extract air combination

1150 – 1500 × 900
1450 – 1800 × 1200
1750 – 2100 × 1500
2050 – 2400 × 1800
2350 – 2700 × 2100
2650 – 3000 × 2400
2950 – 3000 × 2700

9 Width of front frame [mm]

B

593
598
618
623

10 Exposed surface

No entry: powder-coated RAL 9010, pure white

P1 Powder-coated, specify RAL CLASSIC colour

Gloss level
 RAL 9010 50 %
 RAL 9006 30 %
 All other RAL colours 70 %

11 Surface of heat exchanger

No entry: untreated

G3 RAL 9005, black

12 Air control blades

No entry: none

LE With

13 Valves and actuators

No entry: none

VS With

Order examples

DID632-LR-2-M-LL/1193x1200x593

Induced air grille	Perforated metal, circular holes
Heat exchanger	2-pipe
Nozzle variant	Medium
Arrangement of casings and connections	Left side, left side
Total length (diffuser face) × nominal length	1193 × 1200 mm
Width of front frame	593 mm

DID632-GQ-2-U-RR-AV-A1/1798x1200x598/P1/RAL9006/G3/LE/VS

Induced air grille	Transverse blades
Heat exchanger	2-pipe
Nozzle variant	Extra large
Arrangement of casings and connections	Right side, right side
Extract air spigot	Front
Water connections	With G½" external thread and flat seal
Total length (diffuser face) × nominal length	1798 × 1500 mm
Width of front frame	598 mm
Exposed surface	RAL 9006
Surface of heat exchanger	Black
Valves and actuators	With

DID632-LR

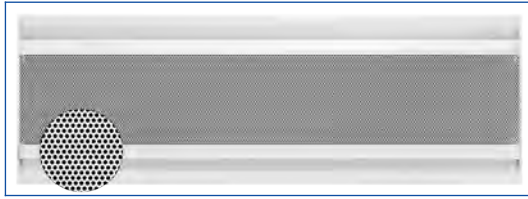

DID632-LQ

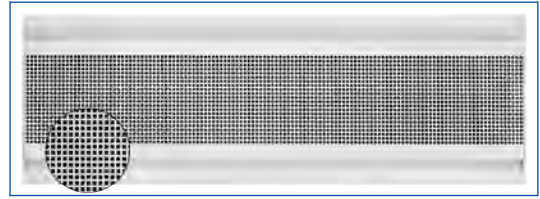

DID632-GQ

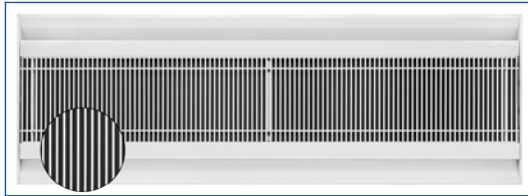

DID632-GL



Set of air control blades

If a high cooling capacity is required in a very small space with active chilled beams, optional air control blades allow for adjusting the air discharge pattern such that the acceptable air velocity in the occupied zone is not exceeded. The airflow of each active chilled beam is spread and discharged according to the room geometry. If the use of a room changes, the air discharge pattern can be optimised by adjusting the air control blades accordingly.

- It is possible to adjust several air control blades (i.e. a set of air control blades) together
- For fine adjustment, the sets of air control

- blades can be disconnected from complementary to one another
- To adjust a set of air control blades, use both hands to move the two outer blades of the set as required
 - Maximum possible adjustment is 45° to the right or left in steps of 15°
 - The blades are factory set to straight air discharge

If the air discharge is not straight, the water-side capacity will be slightly affected. Blades set at 45° may cause a loss of up to 5 %. Air control blades have to be factory fitted; it is not possible to retrofit air control blades at a later stage.

Set of air control blades

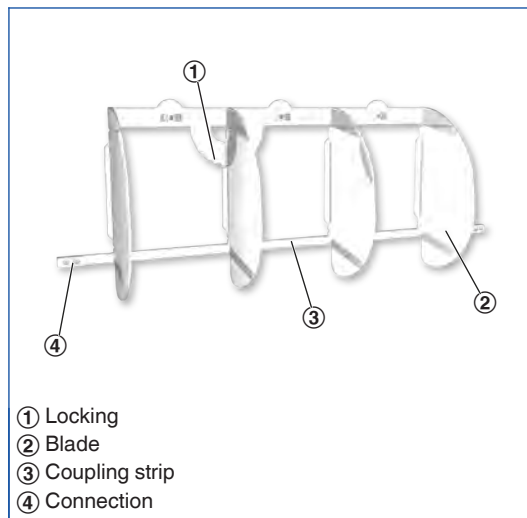

Straight air discharge

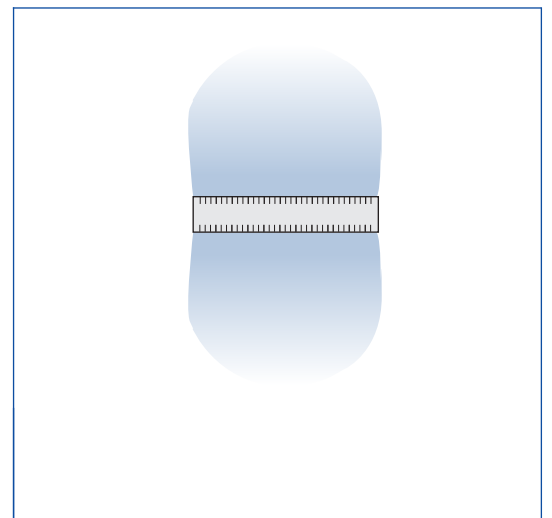

Angled air discharge

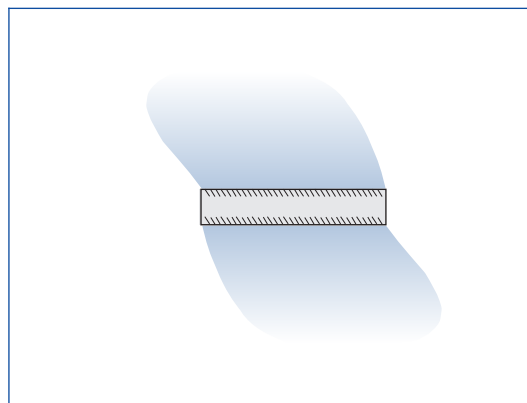

Divergent air discharge

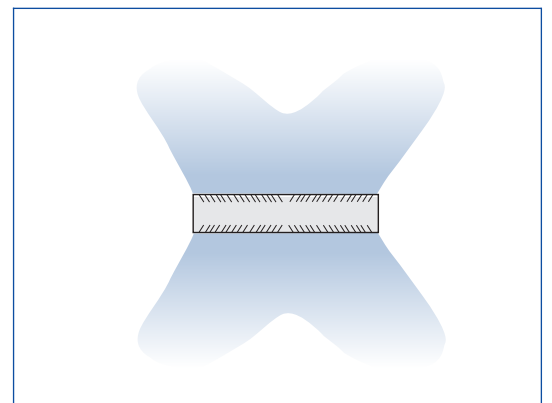

DID632-...-LR

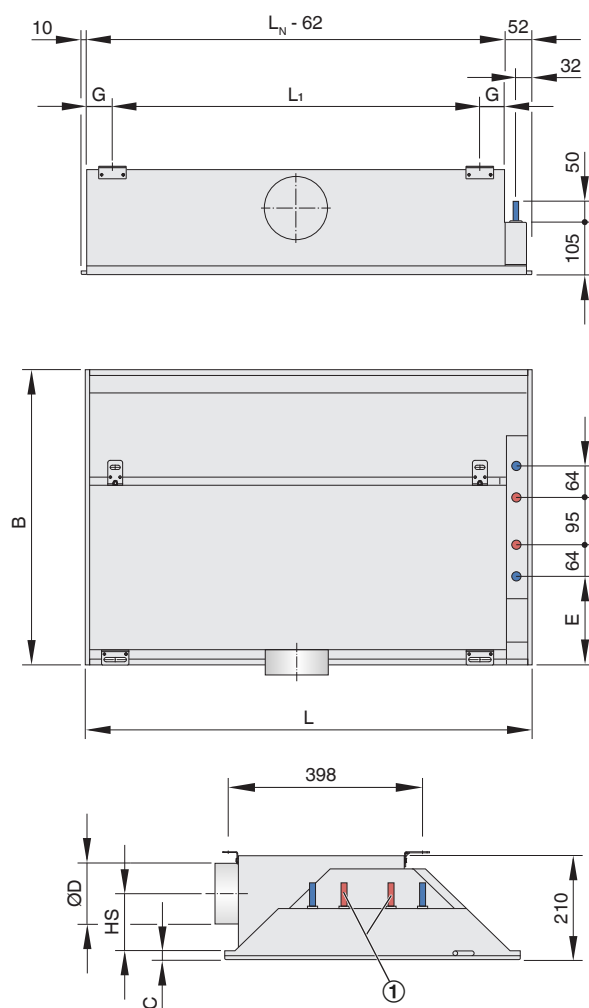

Water connection, Ø12 mm pipe, either with plain tails
or with G $\frac{1}{2}$ " external thread
① Only with 4-pipe system

Dimensions [mm]

B	C	E
593	18	178
598	8	180
618	18	190
623	8	193

B = Width of front frame

Dimensions [mm]

L _N	L	ØD	HS	G
900	893 – 1500	123	134	51.5
1200	1193 – 1800	123	134	51.5
1500	1493 – 2100	123	134	51.5
1800	1793 – 2400	123	134	351.5
2100	2093 – 2700	158	116	361.5
2400	2393 – 3000	158	116	451.5
2700	2693 – 3000	158	116	561.5
3000	2993 – 3000	158	116	651.5

L = Total length (diffuser face)

L_N = Nominal length

Weight per unit [kg]

Nominal length (L _N)	900	1200	1500	1800	2100	2400	2700	3000
DID632-LR	18	22	27	32	39	47	54	61
DID632-LQ	17	21	26	31	38	46	53	60
DID632-GL	20	25	31	36	43	52	59	67
DID632-GQ	20	25	31	36	43	52	59	67
Contained water (max.)	1.8	2.4	3	3.6	4.2	4.8	5.4	6

Non-active section as extension: 10 kg/m

Differences in width can be neglected

Casing arrangement

Supply air

DID632-...-MR¹

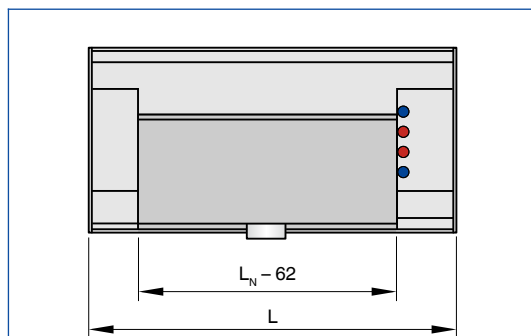

¹Construction MR is only available from
 $L = L_N + 200$ mm.

Casing: centre
Water connections: right side

DID632-...-ML¹

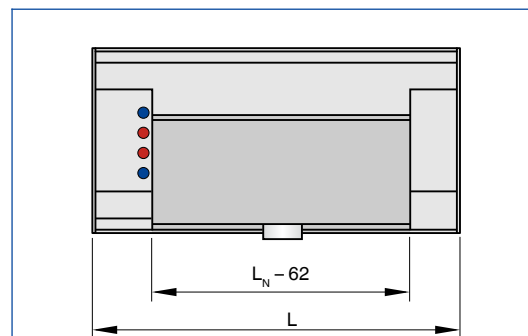

¹Construction ML is only available from
 $L = L_N + 200$ mm.

Casing: centre
Water connections: left side

DID632-...-RR¹

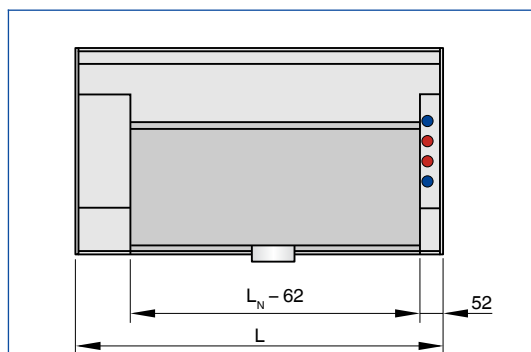

¹Construction RR is only available from
 $L = L_N + 200$ mm.

Casing: right side
Water connections: right side

DID632-...-LL¹

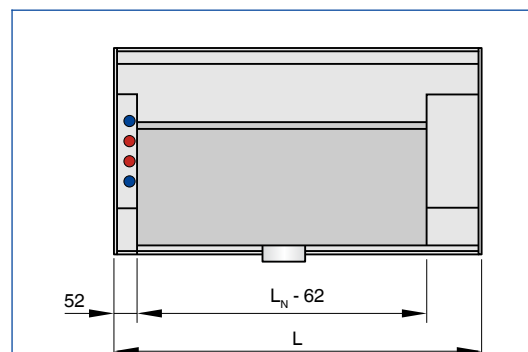

¹Construction LL is only available from
 $L = L_N + 200$ mm.

Casing: left side
Water connections: left side

DID632-...-LR

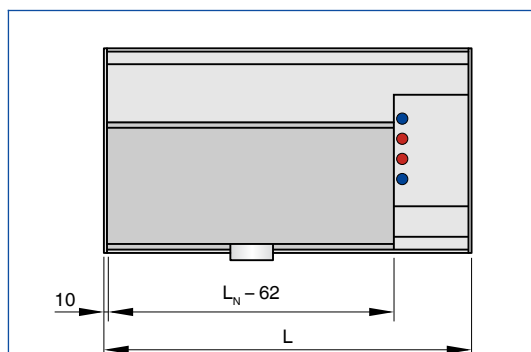

Casing: left side
Water connections: right side

DID632-...-RL

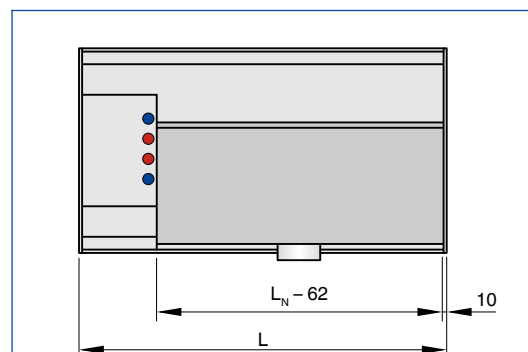

Casing: right side
Water connections: left side

Type DID632-...-RR-AV

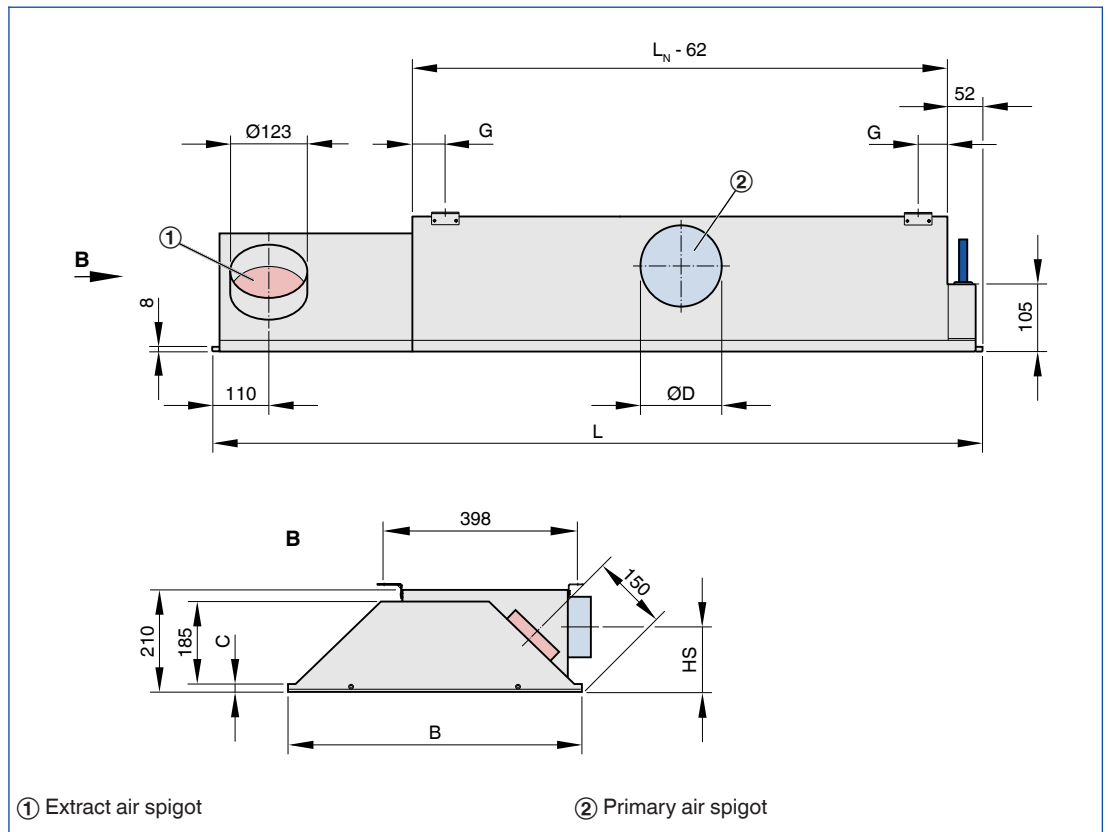

Dimensions [mm]

B	C
593	18
598	8
618	18
623	8

B = Width of front frame

Dimensions [mm]

L _N	L	ØD	HS	G
900	1150 – 1500	123	134	51.5
1200	1450 – 1800	123	134	51.5
1500	1750 – 2100	123	134	51.5
1800	2050 – 2400	123	134	351.5
2100	2350 – 2700	158	116	361.5
2400	2650 – 3000	158	116	451.5
2700	2950 – 3000	158	116	561.5

L = Total length (diffuser face)

L_N = Nominal length

Weight per unit [kg]

Nominal length (L _N) in mm	900	1200	1500	1800	2100	2400	2700	3000
DID632-LR	18	22	27	32	39	47	54	61
DID632-LQ	17	21	26	31	38	46	53	60
DID632-GL	20	25	31	36	43	52	59	67
DID632-GQ	20	25	31	36	43	52	59	67
Contained water (max.)	1.8	2.4	3	3.6	4.2	4.8	5.4	6

Non-active section as extension: 10 kg/m

Extract air spigot Ø123 mm (min. length 250 mm) 3 kg/piece

Differences in width and LE can be neglected

Casing arrangement

Supply and extract air combination

DID632-...-RR-AV

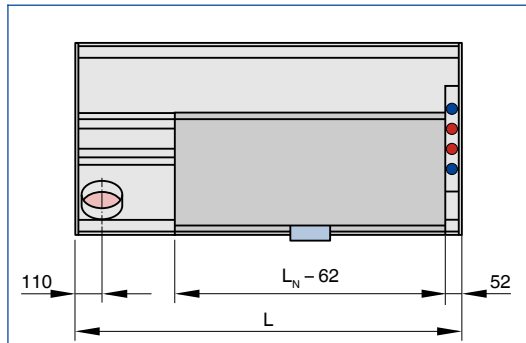

Supply and extract air combination is only available with arrangement LL and RR, and from $L = L_N + 250 \text{ mm}$

Casing: right side
Water connections: right side
Extract air spigot at the front

DID632-...-LL-AV

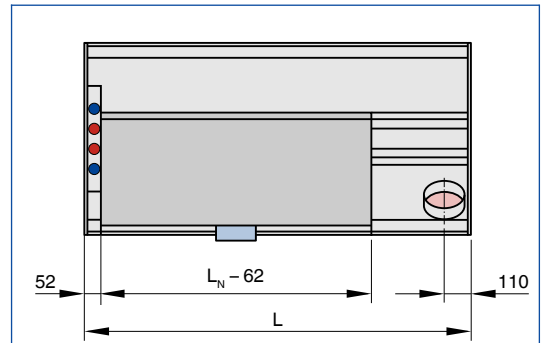

Supply and extract air combination is only available with arrangement LL and RR, and from $L = L_N + 250 \text{ mm}$

Casing: left side
Water connections: left side
Extract air spigot at the front

DID632-...-RR-AH

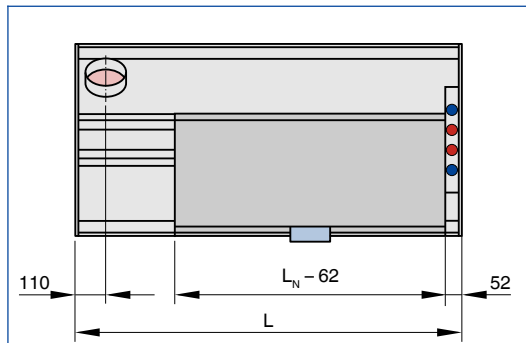

Supply and extract air combination is only available with arrangement LL and RR, and from $L = L_N + 250 \text{ mm}$

Casing: right side
Water connections: right side
Extract air spigot at the rear

DID632-...-LL-AH

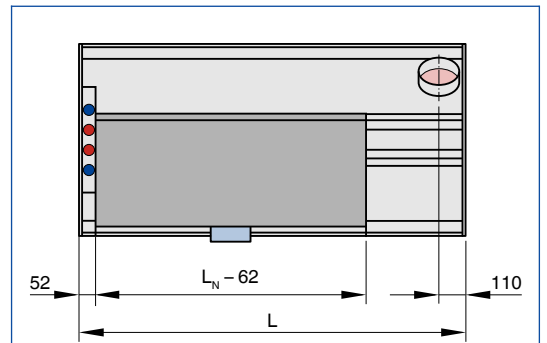

Supply and extract air combination is only available with arrangement LL and RR, and from $L = L_N + 250 \text{ mm}$

Casing: left side
Water connections: left side
Extract air spigot at the rear

Installation into grid ceilings



Installation into T-bar ceilings



Installation into continuous plasterboard ceilings



Installation and commissioning

- Preferably for rooms with a clear height up to 4.0 m
- Flush ceiling installation
- Side entry primary air spigot
- Lengths from 893 to 3000 mm, and widths of 593, 598, 618 and 623 mm, hence suitable for all ceiling systems, particularly for grid ceilings with grid size 600 or 625
- Installation and connections to be performed by others; fixing, connection and sealing material to be provided by others
- Active chilled beam has 4 suspension points for on-site installation (by others)
- Heat exchangers are fitted with water flow and water return connections at the narrow side
- With an extended border also suitable for freely suspended installation

Installation into T-bar ceilings or continuous ceilings

- To avoid too much load on the ceiling, the suspension points should be used

Ceiling installation, visible T-bars

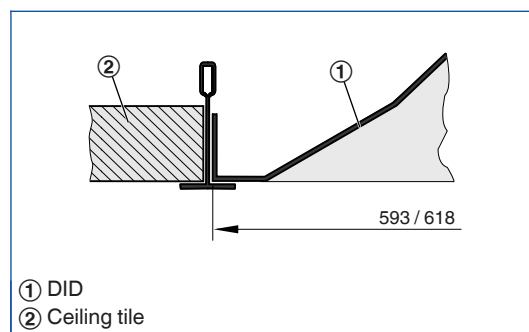

Ceiling installation, concealed T-bars

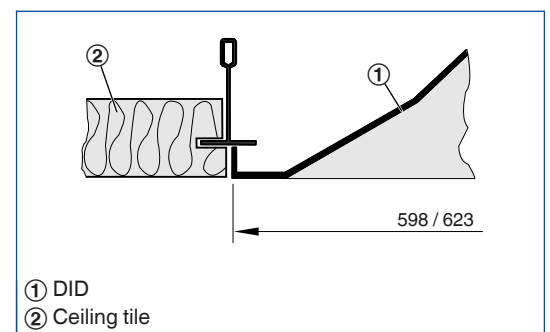

Ceiling installation with clamping profile

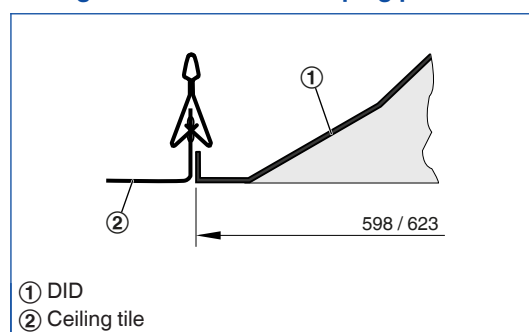

Ceiling installation, plasterboard

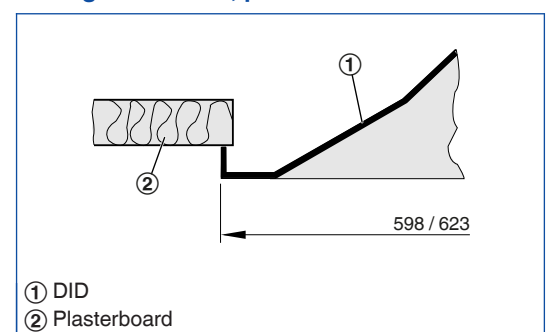

L_N [mm]

Nominal length

L_{WA} [dB(A)]

Sound power level

t_{Pr} [°C]

Primary air temperature

t_{WV} [C°]

Water flow temperature – cooling/heating

t_R [C°]

Room temperature

t_R [C°]

Room temperature

t_{AN} [C°]

Secondary air intake temperature

Q_{Pr} [W]

Thermal output – primary air

Q_{tot} [W]

Thermal output – total

Q_W [W]

Thermal output – water side, cooling/heating

\dot{V}_{Pr} [l/s]

Primary air volume flow rate

\dot{V}_{Pr} [m³/h]

Primary air volume flow rate

\dot{V}_W [l/h]

Water flow rate – cooling/heating

\dot{V} [l/h]

Volume flow rate

Δt_W [K]

Temperature difference – water

Δp_W [kPa]

Pressure drop, water side

Δp_t [Pa]

Total pressure drop, air side

$\Delta t_{Pr} = t_{Pr} - t_R$ [K]

Difference between primary air temperature and room temperature

$\Delta t_{RWV} = t_{WV} - t_R$ [K]

Difference between water flow temperature and room temperature

Δt_{Wm-Ref} [K]

Difference between mean water temperature and reference temperature

L_N [mm]

Nominal length

Mixed flow

The supply air is discharged from the diffuser into the space with a velocity between 2 and 5 m/s. The resulting air jet mixes with the room air, ventilating the entire space. Mixed flow systems typically provide a uniform temperature distribution and air quality within the space. The originally high velocity of the turbulent air jet decreases rapidly due to the high induction levels of mixed flow systems.

Schematische Darstellung Mischlüftung

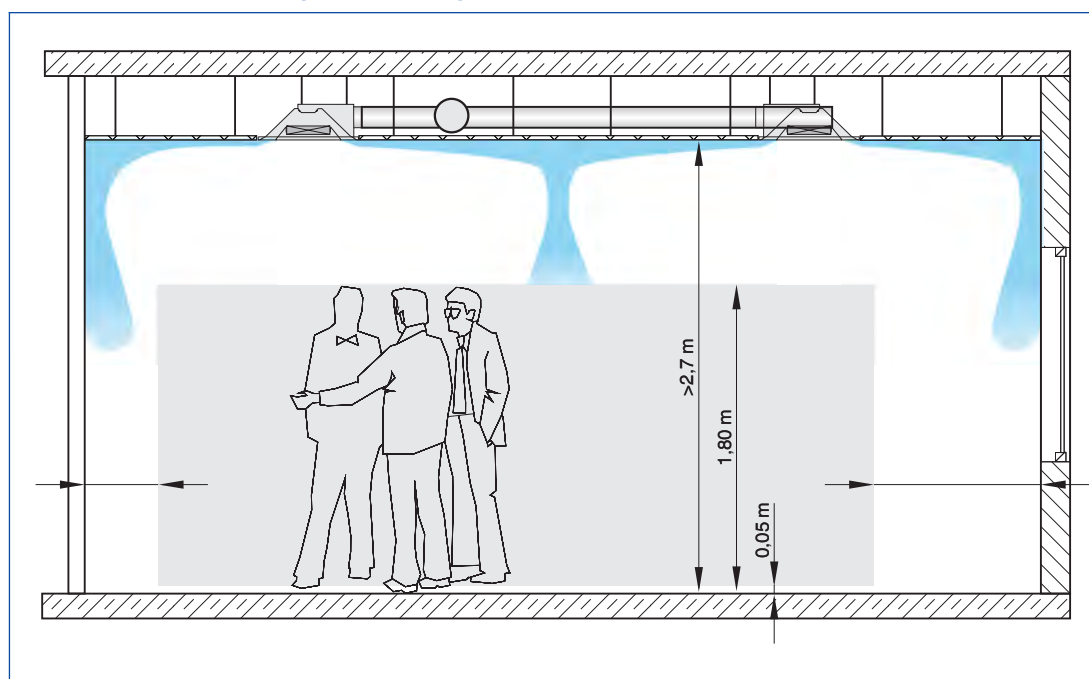

Heat exchanger

The maximum water-side operating pressure for all heat exchangers is 6 bar.
The maximum water flow temperature (heating circuit) for all heat exchangers is 75 °C; if flexible hoses are used, the water flow temperature should not exceed 55 °C. Units for other pressures

and temperatures are available on request.
The water flow temperature (cooling circuit) should be at least 16 °C such that it does not permanently fall below the dew point. For units with a condensate drip tray the water flow temperature may be reduced to 15 °C.

Heat exchanger as 2-pipe system

Air-water systems with a 2-pipe heat exchanger may be used for either heating or cooling. In

changeover mode it is possible to use all units within a water circuit exclusively for cooling in summer and exclusively for heating in winter.

Wärmeübertrager 2-Leiter-System



Heat exchanger as 4-pipe system

Air-water systems with a 4-pipe heat exchanger may be used for both heating and cooling. Depending on the season, i.e. especially in spring

and autumn, it may be possible that an office has to be heated in the morning and cooled in the afternoon.

Wärmeübertrager 4-Leiter-System

