

Ventilation grilles for installation into walls, sills or rectangular ducts

Type TR

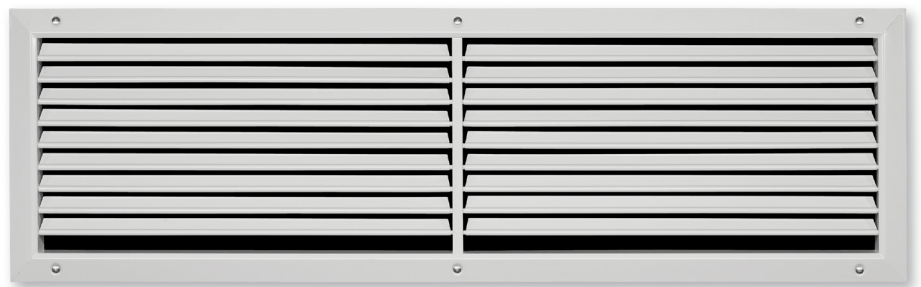

Ventilation grilles, made of sheet steel, with individually adjustable, horizontal blades

Ventilation grille with droplet shaped blades

- Nominal sizes 225 × 125 – 1225 × 525 mm
- Volume flow rate range 23 – 2000 l/s or 83 – 7200 m³/h
- Grille face made of sheet steel, powder-coated
- Front border with countersunk holes, 27 mm wide

Optional equipment and accessories

- Grille face in RAL CLASSIC colours
- Grille face made of galvanised sheet steel, without powder coating
- Installation subframe
- Installation subframe for fitting filter media
- Attachments for volume flow rate balancing and air direction control
- Concealed screw fixing

Type		Page
TR	General information	TR – 2
	Function	TR – 3
	Technical data	TR – 6
	Quick sizing	TR – 7
	Specification text	TR – 8
	Order code	TR – 9
	Dimensions and weight	TR – 11
	Product details	TR – 12
	Installation examples	TR – 13
	Installation details	TR – 14
	Commissioning	TR – 15
	Basic information and nomenclature	TR – 16

Application

Application

- Ventilation grille of Type TR as supply air or extract air variant for comfort zones and industrial zones
- Directed supply air discharge for mixed flow ventilation
- Blades are adjustable to meet different local requirements
- For variable and constant volume flows
- For supply air to room air temperature differences from –12 to +4 K
- For installation in walls, sills and rectangular ducts

Special characteristics

- Individually adjustable blades
- Countersunk holes or concealed screw fixing
- Optional installation subframe and casing for the fitting of filter media

Nominal sizes

- Nominal length: 225, 325, 425, 525, 625, 825, 1025, 1225 mm
- Nominal height: 125, 225, 325, 425, 525 mm

Other dimensions upon request

Description

Variants

Fixing

- Countersunk holes
- C11: Concealed screw fixing

Parts and characteristics

- Sloped border with chamfered inside edge
- Individually adjustable, horizontal blades
- Factory fitted perimeter seal
- Vertical centre mullion for nominal lengths over 625 mm

Attachments

- AG, AS, D, DG: For volume flow rate balancing and for air direction control

Accessories

- Installation subframe: For the fast and simple installation of ventilation grilles
- Filter casing: Frame with filter element and spring clip fixing

Construction features

- Asymmetrically supported blades

- Border with countersunk holes or concealed screw fixing

Materials and surfaces

- Border and blades made of galvanised sheet steel
- Border and blades powder-coated RAL 9010, pure white
- P1: Border and blades powder-coated, RAL CLASSIC colour
- S7: Border and blades made of galvanised sheet steel, not powder-coated

Standards and guidelines

- Sound power level of the air-regenerated noise measured according to EN ISO 5135

Maintenance

- Maintenance-free as construction and materials are not subject to wear
- Inspection and cleaning to VDI 6022

Functional description

Ventilation grilles are air terminal devices for the supply air and extract air of ventilation and air conditioning systems. They direct the supply air into the room. Ventilation grilles with adjustable blades allow for adapting the discharge direction to the local conditions. The result is a mixed flow ventilation in comfort zones and industrial zones, with good overall room ventilation. Induction slows the airflow down, i.e. the airflow velocity decreases as the distance from the grille increases. The distance at which the airflow velocity reaches a certain defined value, e.g. 0.2 m/s, is called throw distance. The supply air jet from wall grilles that are installed near the ceiling

achieves a larger throw distance than a free jet (from a grille that is not installed near the ceiling). Single grilles, groups of grilles and continuous horizontal runs all achieve different throw distances.

In cooling mode it is necessary to take account of the jet deviation towards the occupied zone, which increases as the supply air to room air temperature difference increases and the discharge velocity decreases. In heating mode the supply air jet deviates towards the ceiling. This has no negative effect on the airflow velocity in the occupied zone, but it may affect the complete ventilation of the room.

Schematic illustration of a ventilation grille with longitudinal blades

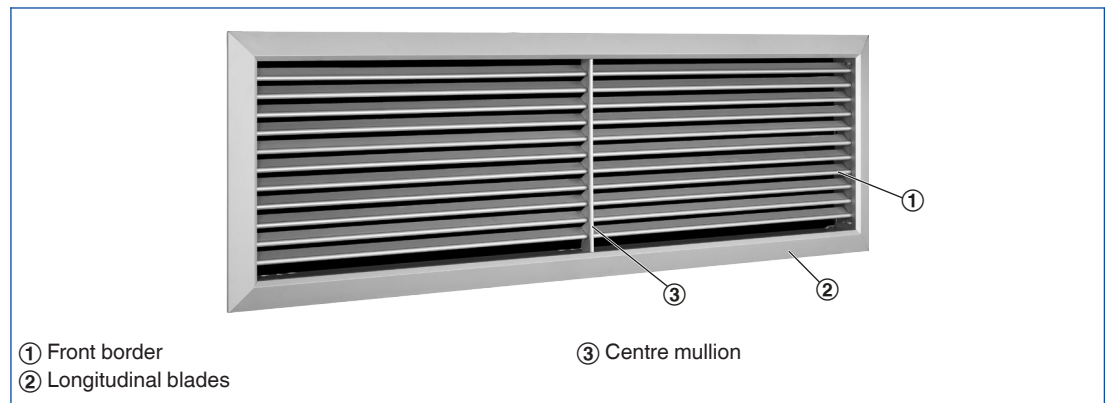

Air pattern in cooling mode, with ceiling effect, sectional view

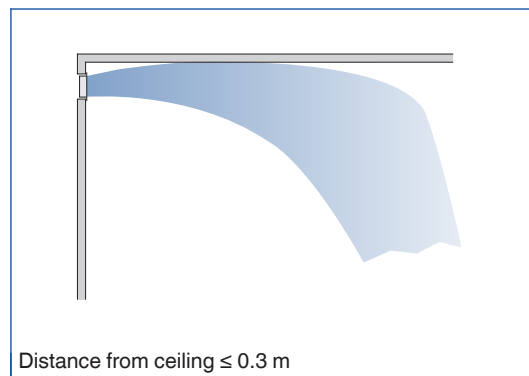

Air pattern in cooling mode, without ceiling effect, sectional view

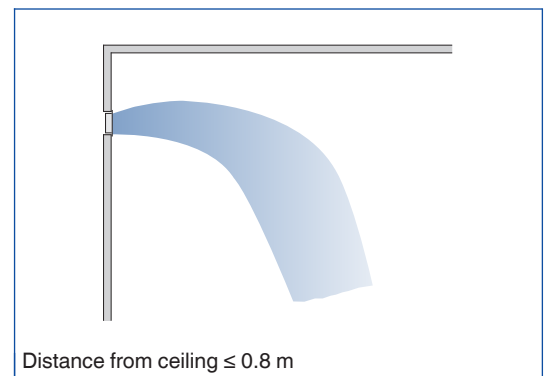

Air pattern with ceiling effect, sectional view

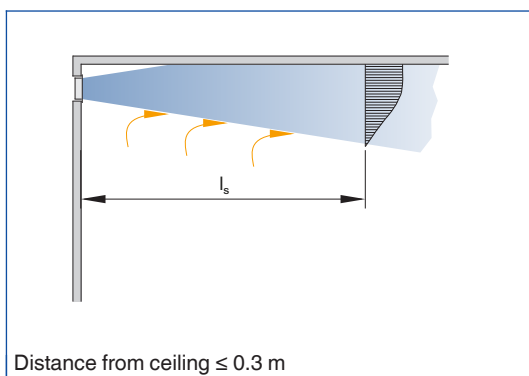

Air pattern without ceiling effect, sectional view

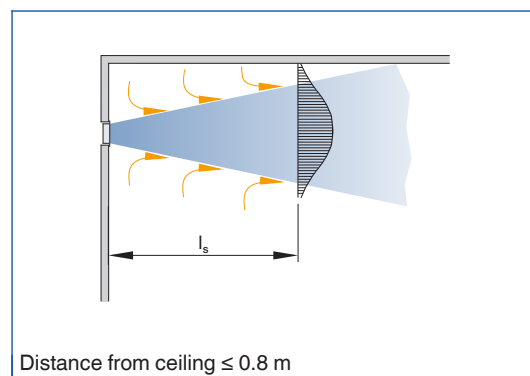

Air pattern with ceiling effect, top view

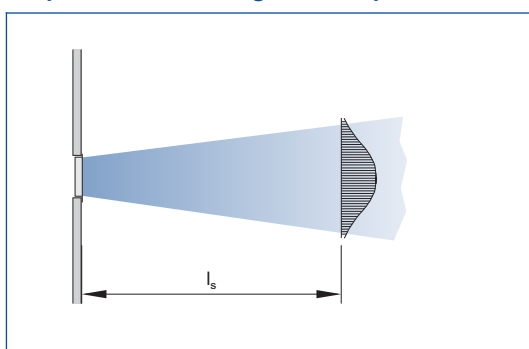

Air pattern without ceiling effect, top view

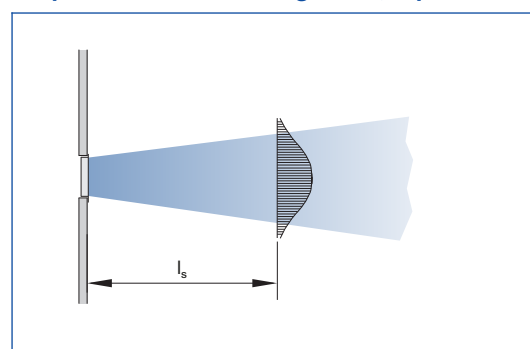

Air pattern with ceiling effect, group of grilles, top view

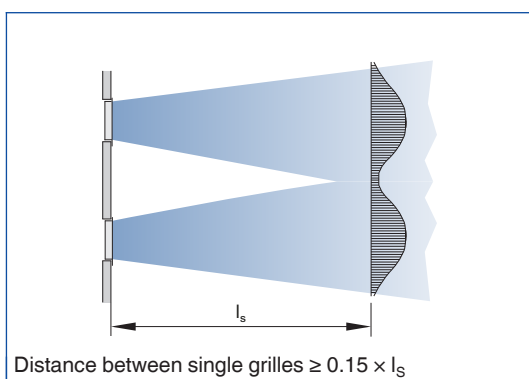

Air pattern without ceiling effect, group of grilles, top view

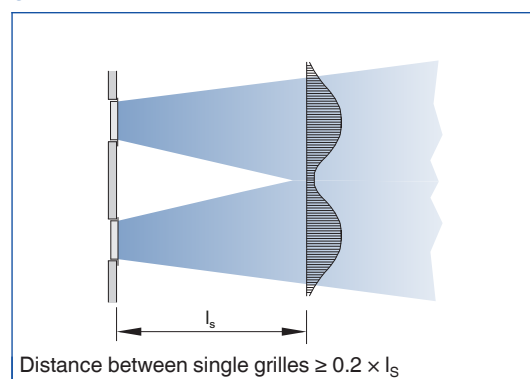

Air pattern, group of grilles, top view

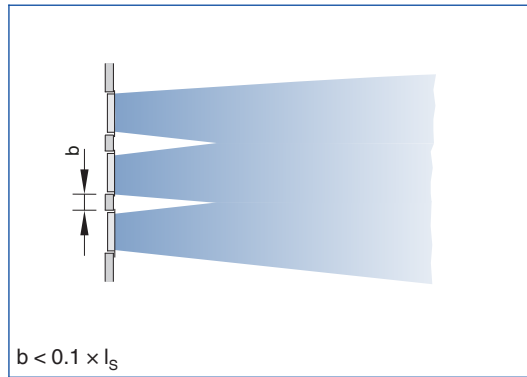

Several single grilles arranged in a row and with not much distance between them have the same effect as a continuous horizontal run.

Nominal sizes	225 × 125 to 1225 × 525 mm
Minimum volume flow rate	23 – 685 l/s or 83 – 2466 m ³ /h
Maximum volume flow rate, with L _{WA} max. 40 dB(A) without attachments	115 – 2000 l/s or 414 – 7200 m ³ /h
Supply air to room air temperature difference	-12 to +4 K

Volume flow rates apply to supply air

Geometric free area

H	L [mm]							
	225	325	425	525	625	825	1025	1225
	A_{geo} m ²							
mm								
125	0.016	0.023	0.031	0.039	0.047	0.062	0.077	0.093
225	0.030	0.046	0.061	0.076	0.092	0.121	0.152	0.182
325		0.068	0.098	0.128	0.158	0.181	0.226	0.272
425					0.181	0.240	0.301	0.361
525							0.375	0.451

Effective air discharge area (supply air)

H	L [mm]							
	225	325	425	525	625	825	1025	1225
	A_{eff} m ²							
mm								
125	0.014	0.021	0.029	0.036	0.043	0.057	0.072	0.086
225	0.029	0.043	0.057	0.072	0.086	0.114	0.142	0.172
325		0.064	0.086	0.108	0.129	0.172	0.214	0.256
425					0.172	0.228	0.285	0.342
525							0.355	0.427

Effective area of extract air grille

H	L [mm]							
	225	325	425	525	625	825	1025	1225
	A_{eff} m ²							
mm								
125	0.011	0.016	0.022	0.028	0.033	0.044	0.055	0.066
225	0.022	0.033	0.044	0.055	0.066	0.090	0.110	0.134
325		0.050	0.066	0.083	0.100	0.134	0.170	0.200
425					0.134	0.180	0.220	0.270
525							0.280	0.340

TR, volume flow rate ranges

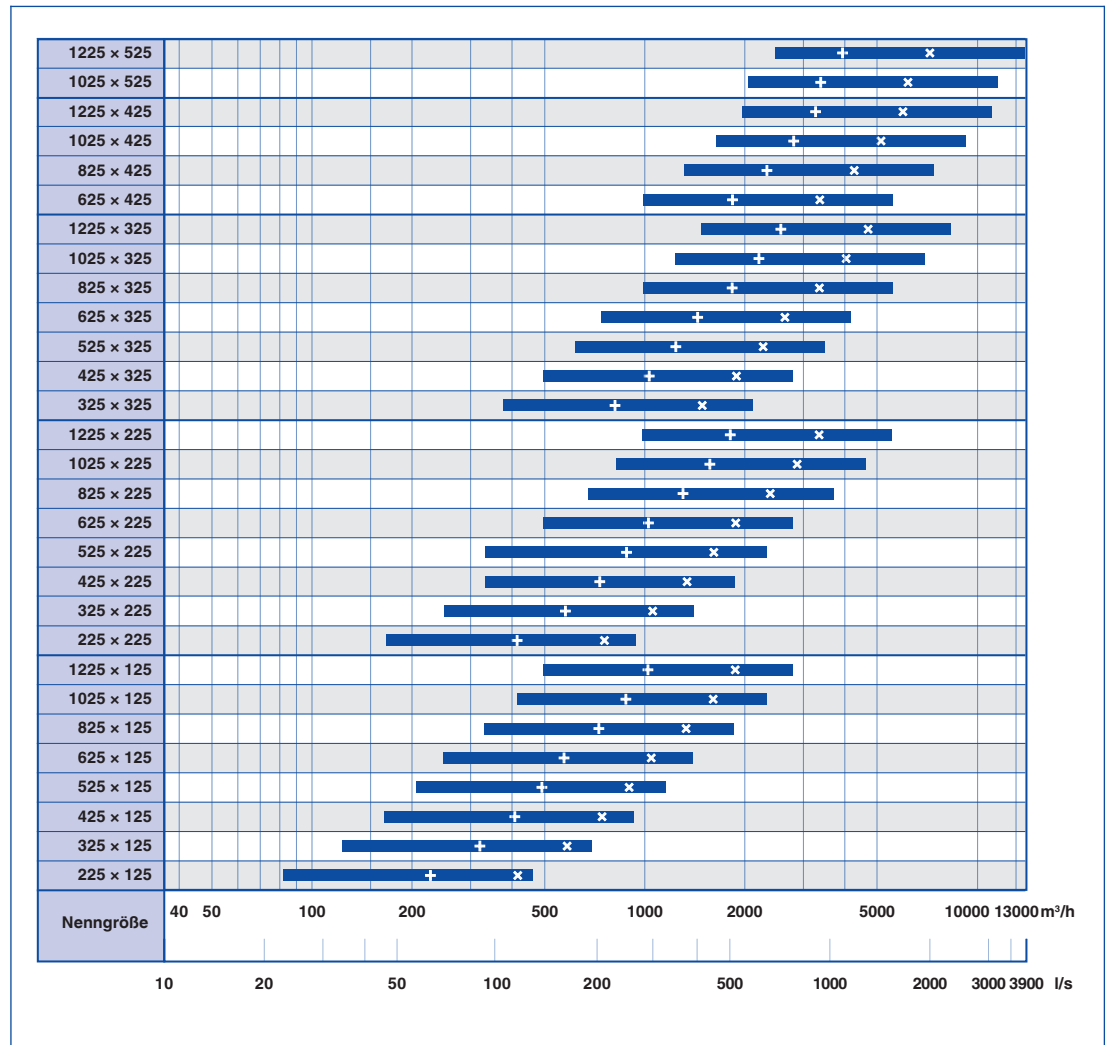

× L_{WA} = 40 dB(A) with unrestricted airflow + L_{WA} = 40 dB(A) with airflow restricted by 50 %

This specification text describes the general properties of the product. Texts for variants can be generated with our Easy Product Finder design programme.

Ventilation grilles, rectangular, made of sheet steel, for supply and extract air. Aesthetic sloped border with chamfered inside edge Preferably for wall and sill installation but also suitable for rectangular ducts.

Ready-to-install component which consists of a border and individually adjustable, horizontal blades.

Concealed screw fixing or countersunk holes, for installation into an installation subframe or fixing onto an installation surface.

Sound power level of the air-regenerated noise measured according to EN ISO 5135.

Special characteristics

- Individually adjustable blades
- Countersunk holes or concealed screw fixing
- Optional installation subframe and casing for the fitting of filter media

Materials and surfaces

- Border and blades made of galvanised sheet steel
- Border and blades powder-coated RAL 9010,

pure white

- P1: Border and blades powder-coated, RAL CLASSIC colour
- S7: Border and blades made of galvanised sheet steel, not powder-coated

Technical data

- Nominal sizes: 225 × 125 to 1225 × 525 mm
- Minimum volume flow rate (supply air): 23 – 685 l/s or 83 – 2466 m³/h
- Maximum volume flow rate (supply air), at L_{WA} max. 40 dB(A) without attachments: 115 – 2000 l/s or 414 – 7200 m³/h
- Supply air to room air temperature difference: -12 to +4 K

Sizing data

- \dot{V} _____
[m³/h]
- Δp_t _____
[Pa]
- Air-regenerated noise
- L_{WA} _____
[dB(A)]

TR

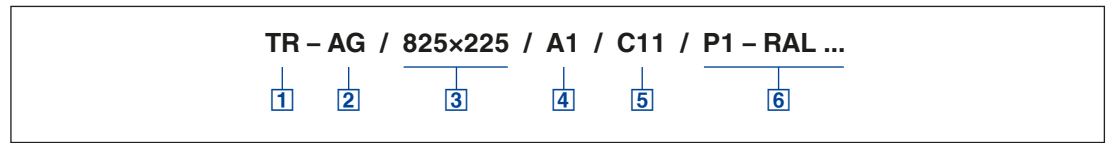

1 Type

TR Single grille

2 Attachments

- A** Without (grille face only)
- AG** Damper unit, opposed action blades
- AS** Hit and miss damper
- D** Air direction control, blades installed at 90° to the front blades, independently adjustable
- DG** D combined with AG

3 Nominal size [mm]

L × H

4 Installation subframe

No entry: none

A1 With

Order example: TR-DG/825x225/A1/C11

Attachments

5 Fixing

No entry: countersunk holes

C11 With concealed screw fixing

6 Exposed surface

No entry: powder-coated

RAL 9010, pure white

P1 Powder-coated, specify RAL CLASSIC colour

S7 Grille face made of galvanised sheet steel, without powder coating

Gloss level

RAL 9010 50 %

RAL 9006 30 %

All other RAL colours 70 %

Damper unit with opposed action blades and air direction control

Nominal size	825 × 225 mm
Installation subframe	With
Fixing	Concealed screw fixing
Exposed surface	Powder-coated RAL 9010, pure white

TR-EF

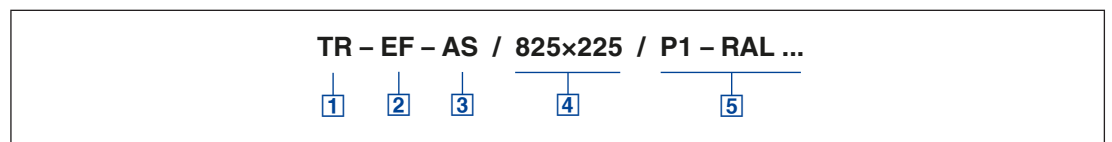

1 Type

TR Single grille

2 Construction

EF Installation subframe with filter element and spring clip fixing

3 Attachments

- A** Without
- AS** Hit and miss damper

4 Nominal size [mm]

L × H

Order example: TR-EF/825x225

Attachments

None

Nominal size 825 × 225 mm

Exposed surface Powder-coated RAL 9010, pure white

5 Exposed surface

No entry: powder-coated

RAL 9010, pure white

P1 Powder-coated, specify RAL CLASSIC colour

Gloss level

RAL 9010 50 %

RAL 9006 30 %

All other RAL colours 70 %

E-EF

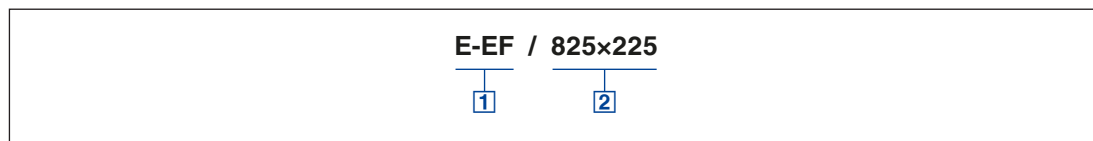

1 Type

E-EF Replacement filter medium

2 Nominal size [mm]

L × H

The weight table shows the available nominal sizes

TR, 27 mm wide front border

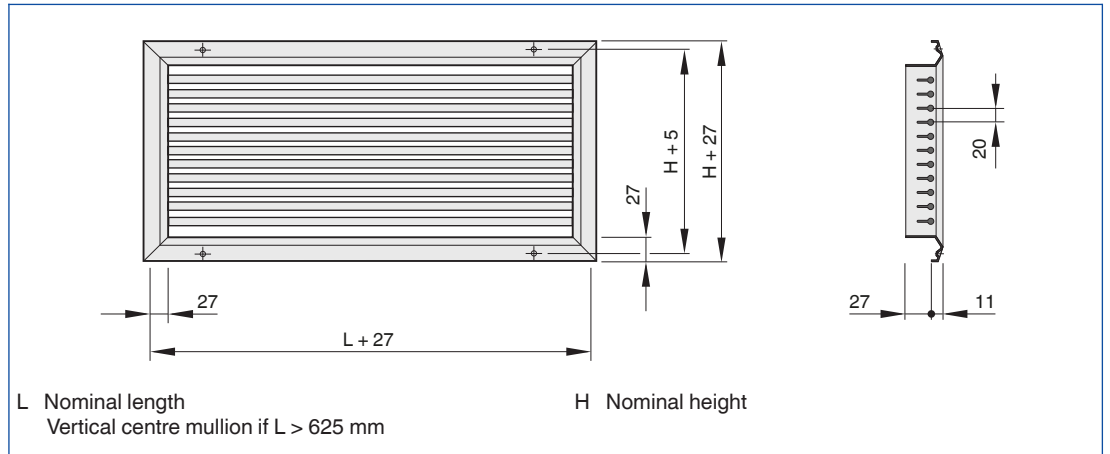

TR

H	L [mm]							
	225	325	425	525	625	825	1025	1225
	m							
mm	kg							
125	0.5	0.6	0.8	1.0	1.1	1.4	1.8	2.1
225	0.8	1.0	1.3	1.5	1.8	2.2	2.7	3.2
325		1.4	1.7	2.0	2.4	3.0	3.7	4.4
425					3.0	3.8	4.6	5.5
525							5.6	6.6

Weights apply to ventilation grilles without attachments

Front border, 27 mm

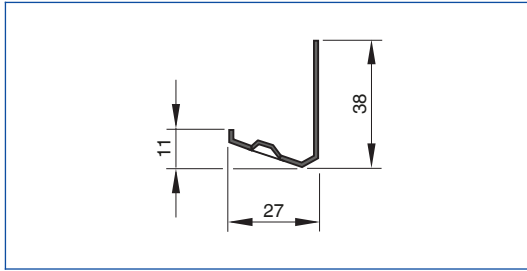

Blade

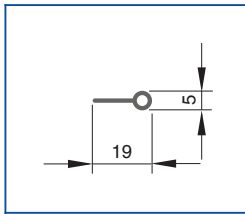

Wall installation



Nominal length over 625 mm: with vertical centre mullion

Installation and commissioning

- Installation preferably in walls, sills and rectangular ducts
- Installation with installation subframe is recommended
- If no installation subframe is used, the border should be fixed with screws

These are only schematic diagrams to illustrate installation details.

Ventilation grille with concealed screw fixing

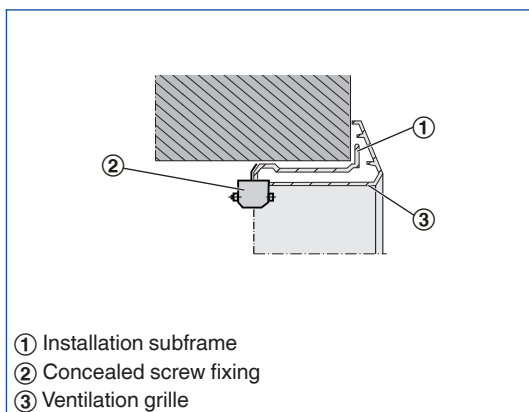

Ventilation grille with spring clip fixing

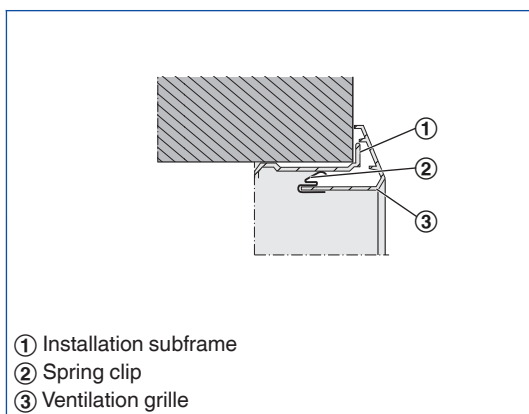

Volume flow rate balancing

When several ventilation grilles are installed on the same duct, it may be necessary to balance the volume flow rates.

- AG: Damper unit with opposed action blades, adjustable, secured with a locking screw
- AS: Damper unit with hit and miss damper, adjustable, secured with a locking screw

Air pattern

- Adjustable blades: Set the air control blades individually or together and depending on the local conditions
- D, DG: Air control blades, fitted at 90° to the front blades, can be adapted to the local conditions

Volume flow rate balancing -*G

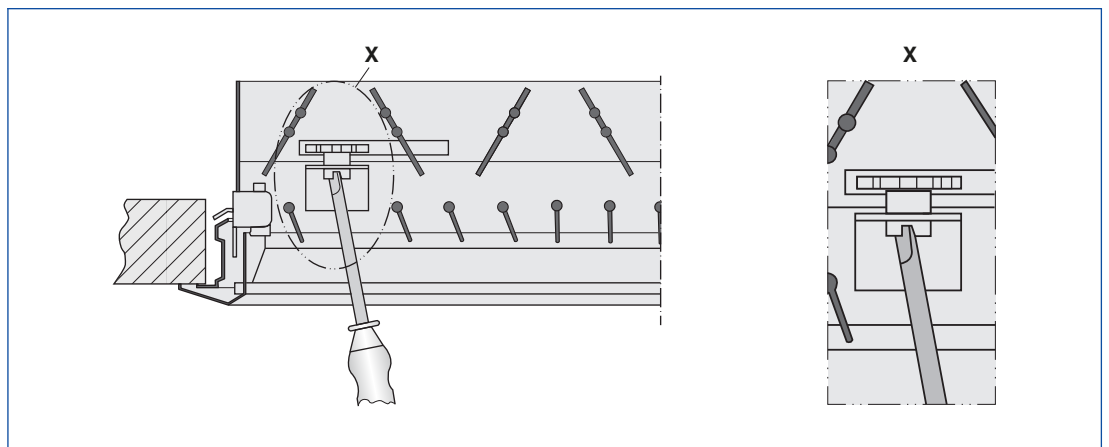

Attachments -AG, -DG and Types AGW, DGW

Volume flow rate balancing -S

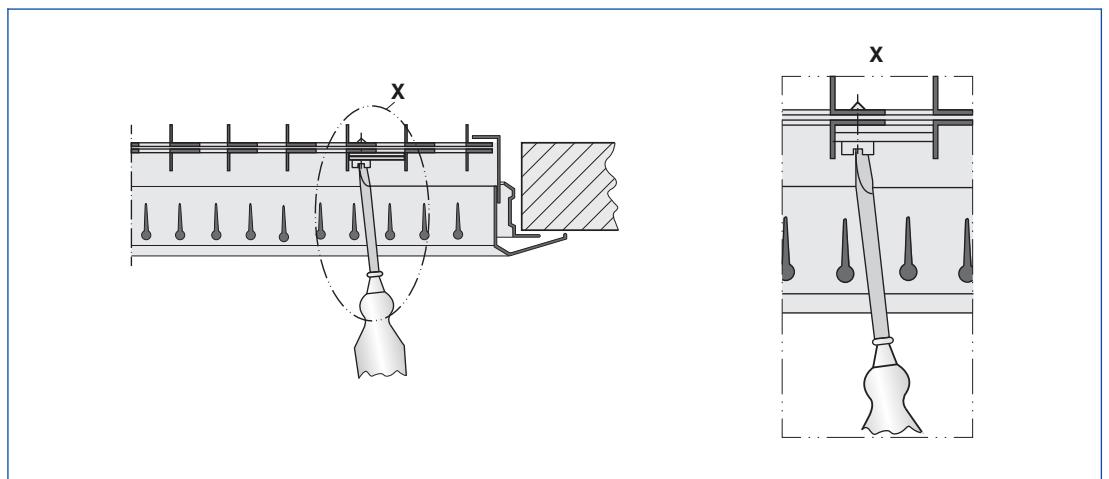

Attachments -AS, -KS, -RS and Type ASW

Principal dimensions

L [mm]

Nominal length of the ventilation grille

H [mm]

Nominal height of the ventilation grille

m [kg]

Weight

Nomenclature

L_{WA} [dB(A)]

Sound power level of the air-regenerated noise

\dot{V} [m³/h] and [l/s]

Volume flow rate

Δp_t [Pa]

Total differential pressure

l_s [m]

Distance from single grille or horizontal run section (throw distance)