



Decentralised ventilation units

Vertical façade ventilation units

FSL-V-ZAB/SEK

SCHOOLAIR-V / -V-1800 / -V-HE / -V-HV



Read the instructions prior to performing any task!

TROX[®] TECHNİK
The art of handling air

TROX GmbH
Heinrich-Trox-Platz
47504 Neukirchen-Vluyn
Germany
Phone: +49 (0) 2845 2020
Fax: +49 (0) 2845 202265
E-mail: trox@trox.de
Internet: <http://www.troxtechnik.com>

A00000055327, 3, GB/en
03/2018

© TROX GmbH 2017

General information

About this manual

This operating and installation manual enables operating or service personnel to correctly install the ventilation unit and to use it safely and efficiently.

This operating and installation manual is intended for use by fitting and installation companies, in-house technicians, technical staff, instructed persons, and qualified electricians or air conditioning technicians.

It is essential that these individuals read and fully understand this manual before starting any work. The basic prerequisite for safe working is to comply with the safety notes and all instructions in this manual.

The local regulations for health and safety at work and the general safety regulations for the area of application of the ventilation unit also apply.

This manual must be given to the system owner when handing over the system. The system owner must include the manual with the system documentation. The manual must be kept in a place that is accessible at all times.

Illustrations in this manual are mainly for information and may differ from the actual design.

Other applicable documentation

- FSL-CONTROL II installation and configuration manual (for units with FSL-CONTROL II control system)
- Project-specific documents (if any)

TROX Technical Service

To ensure that your request is processed as quickly as possible, please keep the following information ready:

- Product name
- TROX order number
- Delivery date
- Brief description of the fault

Online	www.troxtechnik.com
Phone	+49 2845 202-400

Copyright

This document, including all illustrations, is protected by copyright and pertains only to the corresponding product.

Any use without our consent may be an infringement of copyright, and the violator will be held liable for any damage.

This applies in particular to:

- Publishing content
- Copying content
- Translating content
- Microcopying content
- Saving content to electronic systems and editing it

Limitation of liability

The information in this manual has been compiled with reference to the applicable standards and guidelines, the state of the art, and our expertise and experience of many years.

The manufacturer does not accept any liability for damages resulting from:

- Non-compliance with this manual
- Incorrect use
- Operation or handling by untrained individuals
- Unauthorised modifications
- Technical changes
- Use of non-approved replacement parts

The actual scope of delivery may differ from the information in this manual for bespoke constructions, additional order options or as a result of recent technical changes.

The obligations agreed in the order, the general terms and conditions, the manufacturer's terms of delivery, and the legal regulations in effect at the time the contract is signed shall apply.

We reserve the right to make technical changes.

Defects liability

For details regarding defects liability please refer to Section VI, Warranty Claims, of the Delivery and Payment Terms of TROX GmbH.

The Delivery and Payment Terms of TROX GmbH are available at www.troxtechnik.com.

1	Ventilation unit overview.....	5	A	EU declaration of conformity.....	56
1.1	Variants.....	5	B	Product information according to ErP directive.....	57
1.1.1	FSL-V-ZAB/SEK.....	5	C	Declaration of hygiene conformity.....	63
1.1.2	SCHOOLAIR-V.....	6	D	Commissioning report/Maintenance report..	64
1.1.3	SCHOOLAIR-V-1800.....	7			
1.1.4	SCHOOLAIR-V-HE.....	8			
1.1.5	SCHOOLAIR-V-HV.....	9			
1.2	Schematic illustration of the airflows.....	10			
2	Safety.....	12			
2.1	Symbols used in this manual.....	12			
2.2	Correct use.....	12			
2.3	Safety signs.....	13			
2.4	Electric shock hazard.....	13			
2.5	Risks from rotating parts.....	13			
2.6	Health risk due to hygiene issues.....	14			
2.7	Risks caused by an unsuitable installation location.....	14			
2.8	Qualified staff.....	14			
2.8.1	Personal protective equipment.....	14			
3	Transport and storage.....	16			
4	Installation.....	17			
4.1	General installation information.....	17			
4.2	Installing the ventilation unit.....	17			
4.3	Connecting the water pipes.....	19			
4.4	Making electrical connections.....	20			
4.4.1	Wiring.....	21			
4.4.2	FSL-CONTROL II communication.....	26			
5	Initial commissioning.....	30			
6	Control panel settings.....	31			
6.1	Analogue control panel.....	31			
6.2	Digital control panel	32			
7	Control of the ventilation unit.....	34			
8	Maintenance and cleaning.....	35			
8.1	Maintenance.....	36			
8.1.1	Checking and replacing the filters.....	36			
8.1.2	Cleaning the heat exchanger and condensate drip tray.....	37			
8.1.3	Cleaning the heat recovery unit.....	38			
9	Replacement parts list.....	41			
9.1	FSL-V-ZAB/SEK.....	42			
9.2	SCHOOLAIR-V.....	44			
9.3	SCHOOLAIR-V-1800.....	46			
9.4	SCHOOLAIR-V-HE.....	48			
9.5	SCHOOLAIR-V-HV.....	50			
10	Technical data.....	52			
10.1	Technical data.....	52			
11	Index.....	54			
	Appendix.....	55			

1 Ventilation unit overview

1.1 Variants

1.1.1 FSL-V-ZAB/SEK

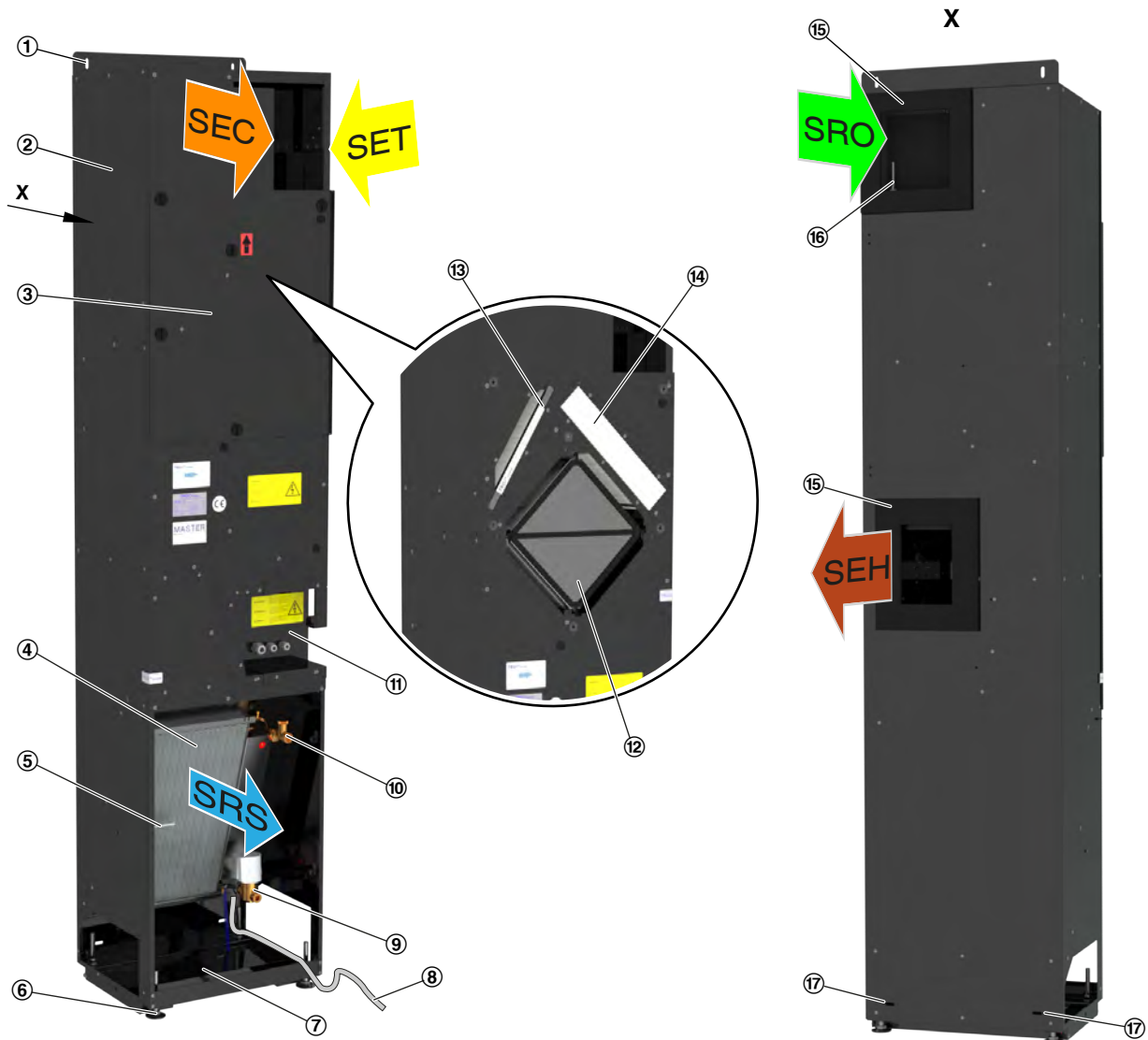

Fig. 1: FSL-V-ZAB/SEK-2L/-4L with 2-pipe or 4-pipe heat exchanger

- | | | | |
|----|---------------------------------|-----|---|
| 1 | Fixing bracket (sliding) | 12 | Cross flow heat recovery unit |
| 2 | Casing | 13 | Extract air filter (flat filter) |
| 3 | Inspection access panel | | G3 coarse dust filter, |
| 4 | 2-pipe or 4-pipe heat exchanger | 14 | Outdoor air filter (Mini Pleat filter) |
| 5 | Supply air temperature sensor | | F7 fine dust filter, |
| 6 | Feet | | filter class to ISO 16890: ISO ePM1 55% |
| 7 | Condensate drip tray | 15 | Seal on the wall side |
| 8 | Power cable | 16 | Outdoor air temperature sensor (optional) |
| 9 | Control valve | 17 | Lower fixing holes |
| 10 | Lockshield | SEH | Single room exhaust air |
| 11 | Controls access panel | SET | Single room extract air |
| | | SRO | Single room outdoor air |
| | | SRS | Single room supply air |
| | | SEC | Secondary air (optional) |

1.1.2 SCHOOLAIR-V

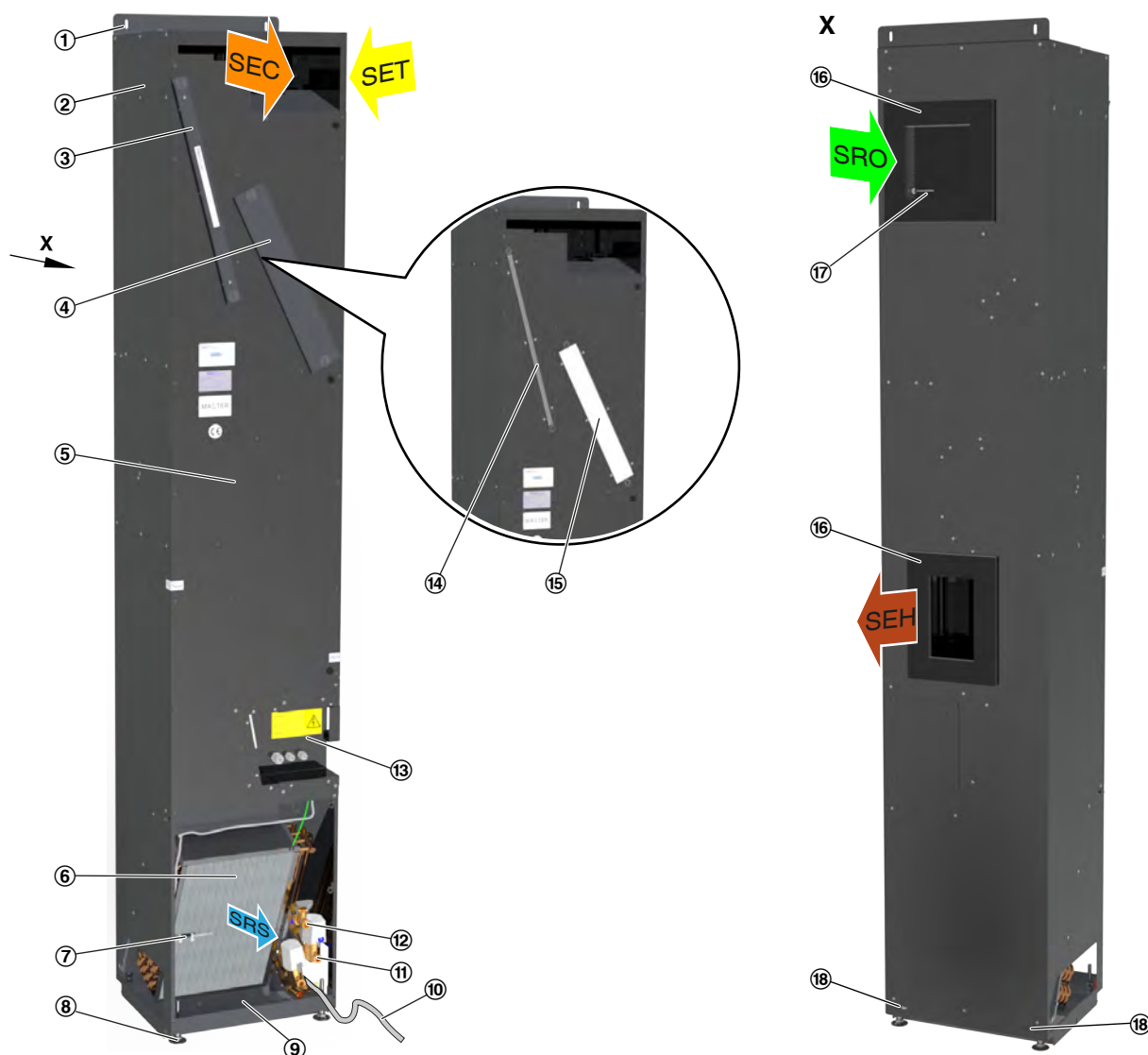

Fig. 2: SCHOOLAIR-V-2L / -4L with 2-pipe or 4-pipe heat exchanger

1	Fixing bracket (sliding)	13	Controls access panel
2	Casing	14	Extract air filter (flat filter) G3 coarse dust filter, filter class to ISO 16890: ISO coarse 50%
3	Extract air filter cover	15	Outdoor air filter (Mini Pleat filter) F7 fine dust filter, filter class to ISO 16890: ISO ePM1 55%
4	Outdoor air filter cover	16	Seal on the wall side
5	Cover plate	17	Outdoor air temperature sensor (optional)
6	2-pipe or 4-pipe heat exchanger	18	Lower fixing holes
7	Supply air temperature sensor	SEH	Single room exhaust air
8	Feet	SET	Single room extract air
9	Condensate drip tray	SRO	Single room outdoor air
10	Power cable	SRS	Single room supply air
11	Control valve	SEC	Secondary air (optional)
12	Lockshield		

1.1.3 SCHOOLAIR-V-1800

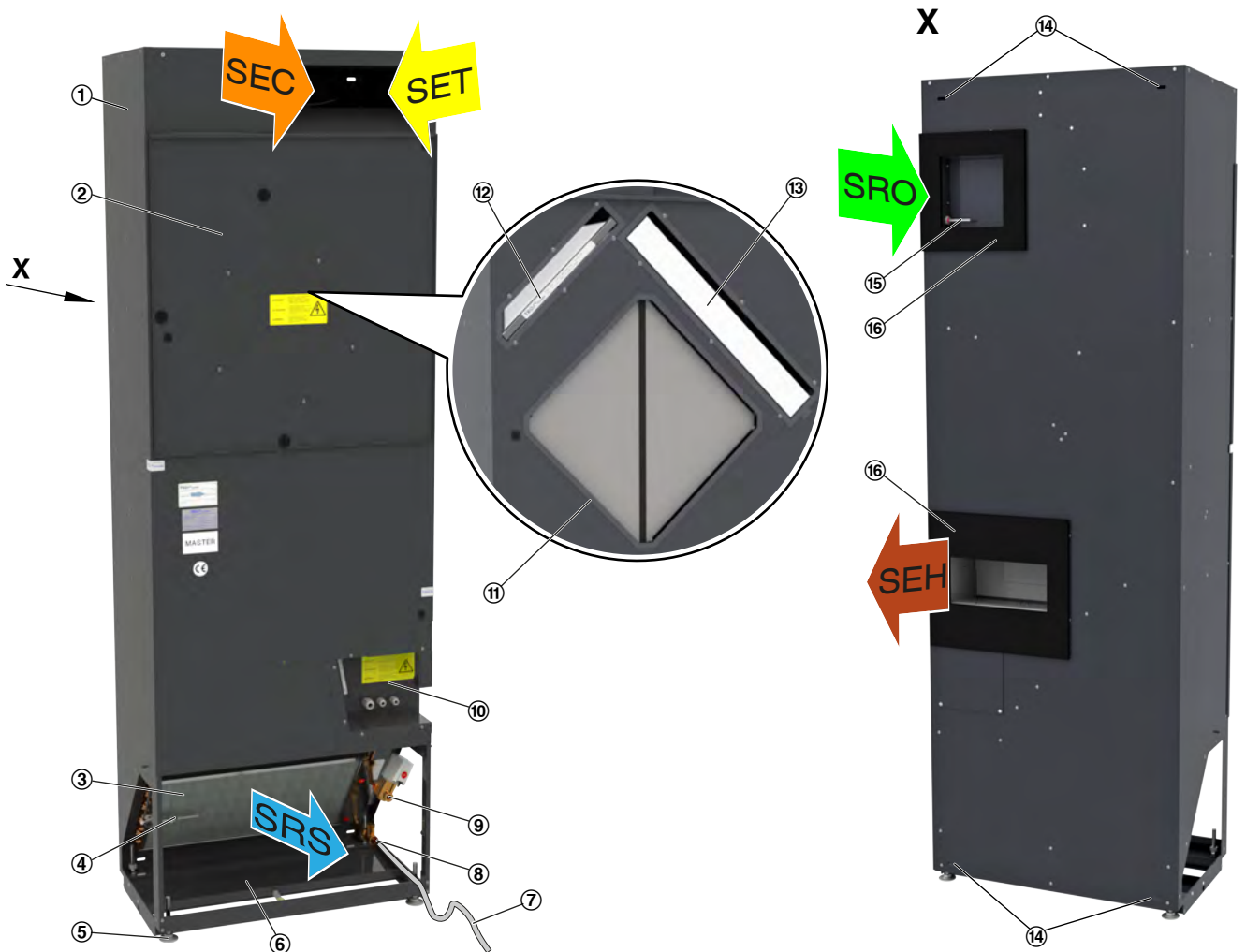

Fig. 3: SCHOOLAIR-V-1800-2L / -4L with 2-pipe or 4-pipe heat exchanger

- | | | | |
|----|---|-----|---|
| 1 | Casing | 12 | Extract air filter (flat filter)
G3 coarse dust filter,
filter class to ISO 16890: ISO coarse 50% |
| 2 | Inspection access panel | 13 | Outdoor air filter (Mini Pleat filter)
F7 fine dust filter,
filter class to ISO 16890: ISO ePM1 55% |
| 3 | 2-pipe or 4-pipe heat exchanger | 14 | Fixing holes |
| 4 | Supply air temperature sensor | 15 | Outdoor air temperature sensor (optional) |
| 5 | Feet | 16 | Seal on the wall side |
| 6 | Condensate drip tray | SEH | Single room exhaust air |
| 7 | Power cable | SET | Single room extract air |
| 8 | Lockshield | SRO | Single room outdoor air |
| 9 | Control valve | SRS | Single room supply air |
| 10 | Controls access panel | SEC | Secondary air (optional) |
| 11 | Cross flow heat exchanger for heat recovery | | |

1.1.4 SCHOOLAIR-V-HE

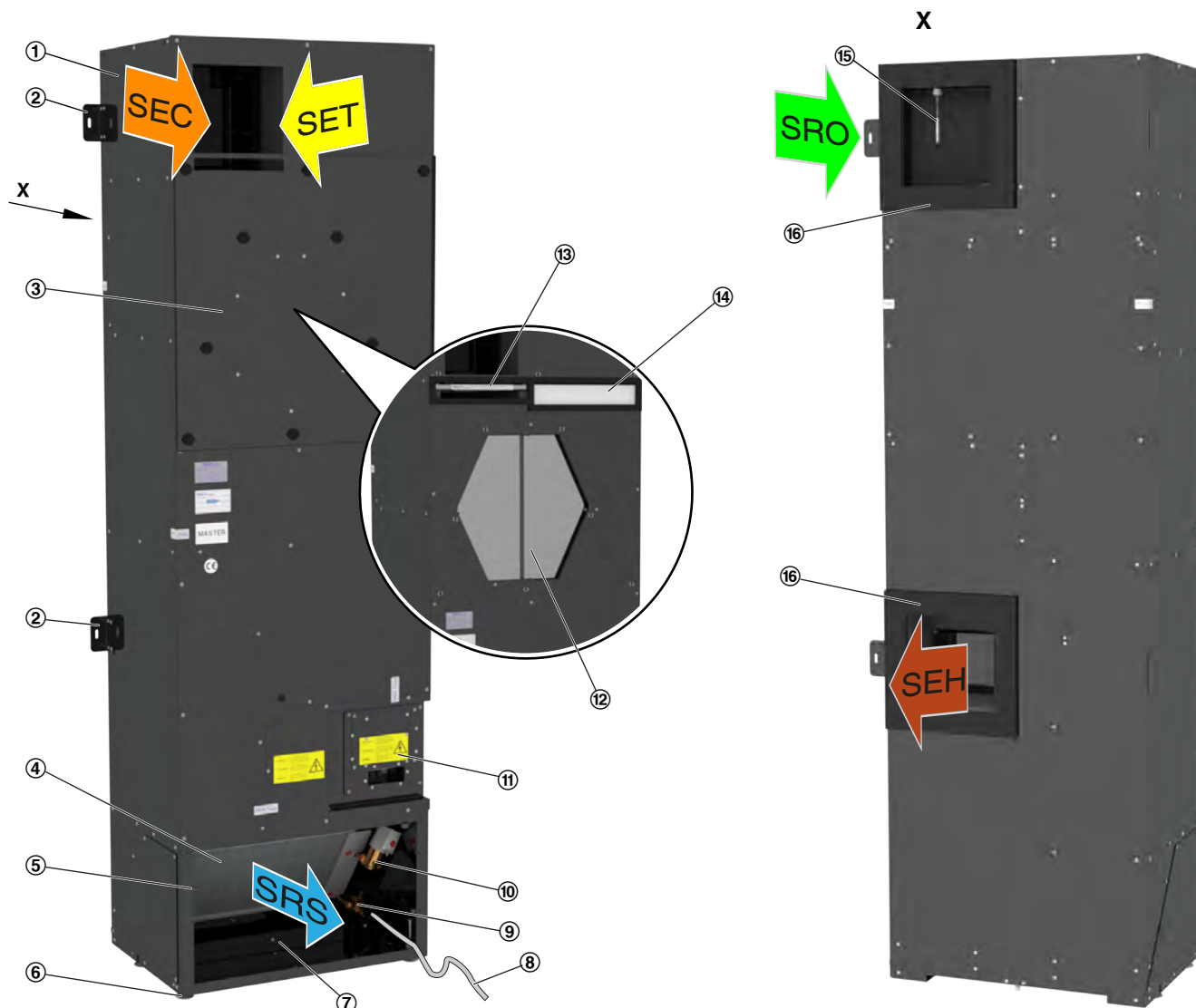

Fig. 4: SCHOOLAIR-V-HE-2L / -4L with 2-pipe or 4-pipe heat exchanger

1	Casing	12	Cross counter flow heat recovery unit
2	Fixing bracket (4 pieces)	13	Extract air filter (flat filter) G3 coarse dust filter, filter class to ISO 16890: ISO coarse 50%
3	Inspection access panel	14 ¹⁾	Outdoor air filter (Mini Pleat filter) F7 fine dust filter, filter class to ISO 16890: ISO ePM1 55%
4	2-pipe or 4-pipe heat exchanger	15	Outdoor air temperature sensor (optional)
5	Supply air temperature sensor	16	Seal on the wall side
6	Feet	SEH	Single room exhaust air
7	Condensate drip tray	SET	Single room extract air
8	Power cable	SRO	Single room outdoor air
9	Lockshield	SRS	Single room supply air
10	Control valve	SEC	Secondary air (optional)
11	Controls access panel		

1) A differential pressure sensor is used to monitor the condition of the outdoor air filter.

1.1.5 SCHOOLAIR-V-HV

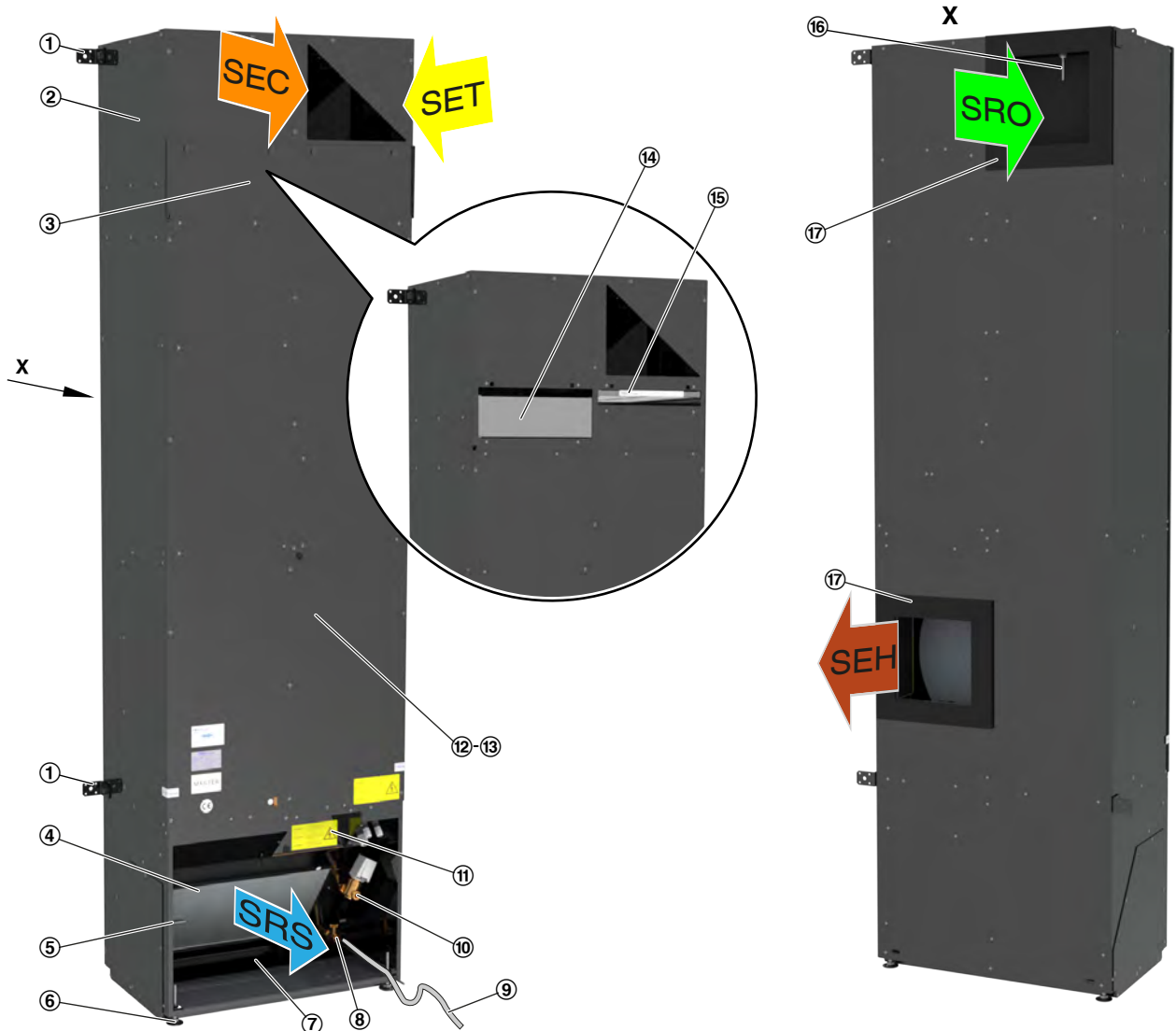

Fig. 5: SCHOOLAIR-V-HV-2L / -4L with 2-pipe or 4-pipe heat exchanger

- | | | | |
|----|--|------------------|---|
| 1 | Fixing bracket (4 pieces, supplied separately) | 12 | Cover plate |
| 2 | Casing | 13 | Rotary heat exchanger (inside) |
| 3 | Inspection access panel | 14 ¹⁾ | Outdoor air filter (Mini Pleat filter)
F7 fine dust filter,
filter class to ISO 16890: ISO ePM1 60% |
| 4 | 2-pipe or 4-pipe heat exchanger | 15 | Extract air filter (flat filter)
G3 coarse dust filter,
filter class to ISO 16890: ISO coarse 50% |
| 5 | Supply air temperature sensor | 16 | Outdoor air temperature sensor (optional) |
| 6 | Feet | 17 | Seal on the wall side |
| 7 | Condensate drip tray | SEH | Single room exhaust air |
| 8 | Lockshield | SET | Single room extract air |
| 9 | Power cable | SRO | Single room outdoor air |
| 10 | Control valve | SRS | Single room supply air |
| 11 | Controls access panel | SEC | Secondary air (optional) |

1) A differential pressure sensor is used to monitor the condition of the outdoor air filter.

1.2 Schematic illustration of the airflows

FSL-V-ZAB/SEK / SCHOOLAIR-V / -V-1800 / -V-HE

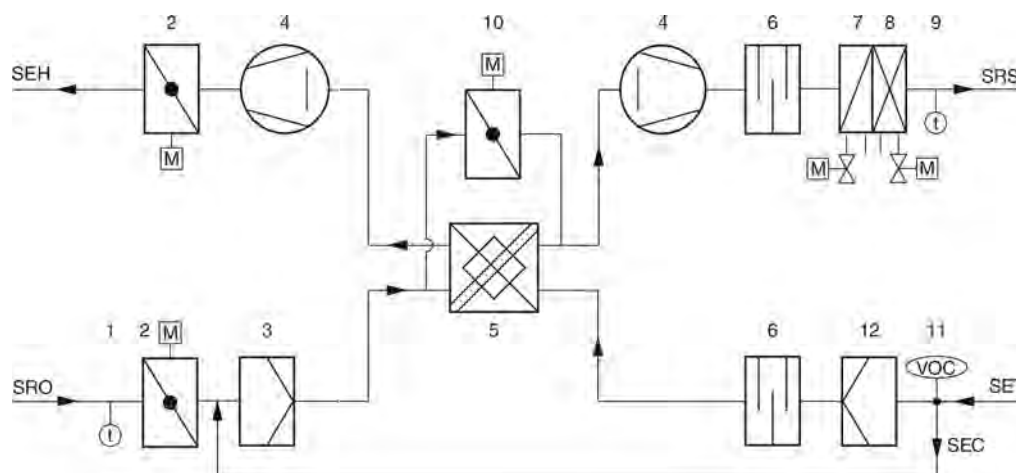

Fig. 6: Ventilation diagram for FSL-V-ZAB/SEK / SCHOOLAIR-V / -V-1800 / -V-HE

- | | | | |
|---|---|-----|-----------------------------|
| 1 | Outdoor air temperature sensor (optional) | 10 | Bypass damper with actuator |
| 2 | Shut-off damper with actuator (exhaust air and outdoor air) | 11 | VOC sensor (optional) |
| 3 | Outdoor air filter | 12 | Extract air filter |
| 4 | Fan (supply air and extract air) | SEH | Single room exhaust air |
| 5 | Recuperative plate heat exchanger:
FSL-V-ZAB / SCHOOLAIR-V / -V-1800: cross flow
SCHOOLAIR-V-HE: cross counter flow | SET | Single room extract air |
| 6 | Sound attenuator | SRO | Single room outdoor air |
| 7 | Heating coil | SRS | Single room supply air |
| 8 | Cooling coil (optional) | SEC | Secondary air (optional) |
| 9 | Supply air temperature sensor | | |

Functional description

Decentralised supply and extract air units for room ventilation and for dissipating cooling loads and heat loads.

An EC centrifugal fan draws in the outdoor air which then passes through the motorised shut-off damper and the F7 filter. The air then flows through the heat recovery unit, which can be bypassed to protect the unit and if it is more energy efficient.

If necessary, the air is heated or cooled by the heat exchanger before it is discharged to the room as a displacement flow (for 4-pipe systems this is optional).

The extract air first passes a G3 filter, then flows through the heat recovery unit, the extract air fan and the motorised shut-off damper before it is discharged to the outside as exhaust air.

If the room air quality is sufficient, FSL-CONTROL II closes the outdoor air dampers and changes to secondary air operation, which is more energy efficient in any case.

The control system compares the room air quality set-point value to the actual value measured by the VOC sensor and switches automatically between outdoor air and secondary air operation.

If the power fails, the outdoor air and exhaust air dampers are closed to ensure fire protection and frost protection and to avoid draughts. This is ensured by a capacitor in each actuator.

SCHOOLAIR-V-HV

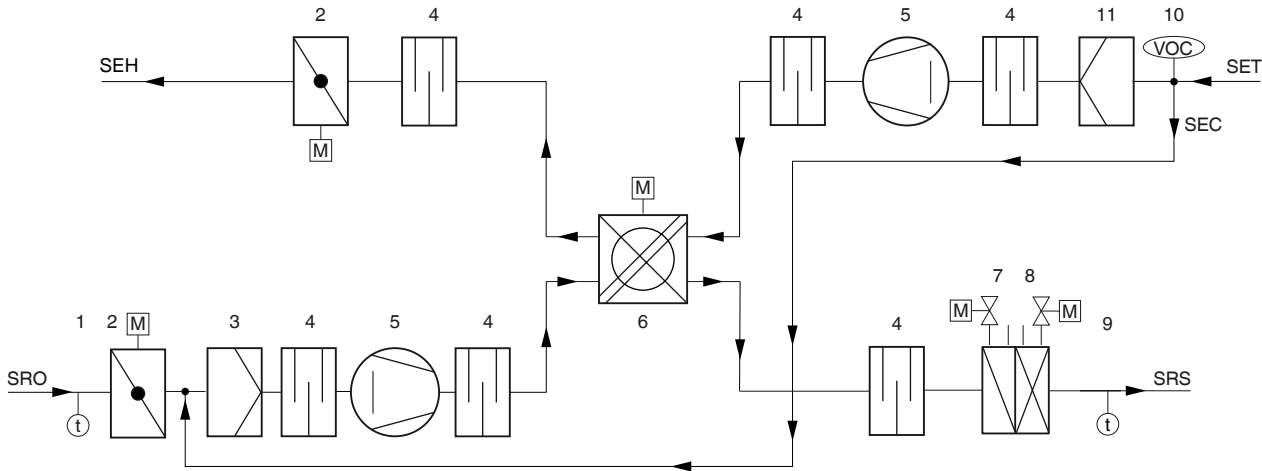

Fig. 7: SCHOOLAIR-V-HV ventilation diagram

- | | | | |
|---|---|-----|-------------------------------|
| 1 | Outdoor air temperature sensor (optional) | 9 | Supply air temperature sensor |
| 2 | Shut-off damper with actuator (exhaust air and outdoor air) | 10 | VOC sensor (optional) |
| 3 | Outdoor air filter | 11 | Extract air filter |
| 4 | Sound attenuator | SEH | Single room exhaust air |
| 5 | Fan (supply air and extract air) | SET | Single room extract air |
| 6 | Rotary heat exchanger for heat recovery | SRO | Single room outdoor air |
| 7 | Heating coil | SRS | Single room supply air |
| 8 | Cooling coil (optional) | SEC | Secondary air (optional) |

Functional description

Decentralised supply and extract air units for room ventilation and for dissipating cooling loads and heat loads.

An EC centrifugal fan draws in the outdoor air which then passes through the motorised shut-off damper and the F7 filter. The air then flows through the rotary heat exchanger for heat recovery, which can be bypassed to protect the unit and if it is more energy efficient.

If necessary, the air is heated or cooled by the heat exchanger before it is discharged to the room as a displacement flow (for 4-pipe systems this is optional).

The extract air first passes a G3 filter, then flows through the heat recovery unit, the extract air fan and the motorised shut-off damper before it is discharged to the outside as exhaust air.

If the room air quality is sufficient, FSL-CONTROL II closes the outdoor air dampers and changes to secondary air operation, which is more energy efficient in any case.

The control system compares the room air quality set-point value to the actual value measured by the VOC sensor and switches automatically between outdoor air and secondary air operation.

If the power fails, the outdoor air and exhaust air dampers are closed to ensure fire protection and frost protection and to avoid draughts. This is ensured by a capacitor in each actuator.

2 Safety

2.1 Symbols used in this manual

Safety notes

Symbols are used in this manual to alert readers to areas of potential hazard. Signal words express the degree of the hazard.

Comply with all safety instructions and proceed carefully to avoid accidents, injuries and damage to property.

DANGER!

Imminently hazardous situation which, if not avoided, will result in death or serious injury.

WARNING!

Potentially hazardous situation which, if not avoided, may result in death or serious injury.

CAUTION!

Potentially hazardous situation which, if not avoided, may result in minor or moderate injury.

NOTICE!

Potentially hazardous situation which, if not avoided, may result in property damage.

ENVIRONMENT!

Environmental pollution hazard.

Safety notes as part of instructions

Safety notes may refer to individual instructions. In this case, safety notes will be included in the instructions and hence facilitate following the instructions. The above listed signal words will be used.

Example:

1. ▶ Untighten the screw.

2. ▶

CAUTION!

Danger of finger entrapment when closing the lid.

Be careful when closing the lid.

3. ▶ Tighten the screw.

Tips and recommendations



Useful tips and recommendations as well as information for efficient and fault-free operation.

Additional markers

In order to highlight instructions, results, lists, references and other elements, the following markers are used in this manual:

Marker	Explanation
1., 2., 3. ...	Step-by-step instructions
	Results of actions
	References to sections in this manual and to other applicable documents
	Lists without a defined sequence
[Switch]	Operating elements (e.g. push buttons, switches), display elements (e.g. LEDs)
'Display'	Screen elements (e.g. buttons or menus)

2.2 Correct use

Decentralised ventilation units are used to create a comfortable room temperature and to ventilate rooms such as offices, meeting rooms, or classrooms in schools.

Functions of the ventilation unit

- Ventilation
- Outdoor air filtering
- Heating and/or cooling (optional)

The ventilation unit is designed for frost-proof installation in buildings, on the inside of an external wall. The unit has to be properly installed on the external wall (by others).

Correct use also involves complying with all the information provided in this manual.

Any use that goes beyond the correct use or any different use of the unit is regarded as incorrect use.

Incorrect use

WARNING!

Danger due to incorrect use!

Incorrect use of the unit can lead to dangerous situations.

Incorrect use includes:

- Any use that is not described in this operating manual
- Operation that does not comply with the technical data
- Modifying of the unit by others, tampering with the unit
- Use, installation, operation, maintenance or repair other than described in this manual
- Having work carried out by unqualified individuals
- Use of non-genuine replacement parts or accessories, whose quality and function are not equivalent to those of the original parts
- Operation in rooms with explosive gases or gas mixtures
- Operation in rooms where the supply or extract air contains particles that are conductive, aggressive, corrosive, combustible or hazardous to health
- Operation in rooms where the humidity is permanently high (> 90 %)
- Operation outdoors
- Use for enforced ventilation
- Operation without air filters

2.3 Safety signs

The following symbols and signs are found on the unit. They apply to the very location where they are found.

Electrical voltage



Hazardous electrical voltage that is present in the ventilation unit. Only skilled qualified electricians are allowed to work on parts of the ventilation unit marked with this symbol. Such work must be carried out only by skilled qualified electricians or the technical service.

Controls access panel



Only skilled qualified electricians are allowed to open the controls access panel. Ensure that no voltage is present on any mains circuit before you open the cover to access the terminal connections.

2.4 Electric shock hazard

Electric current

DANGER!

Danger of death due to electric current!

Danger of electric shock! Do not touch any live components! Damaged insulation or damaged parts are a life threatening hazard.

- Only a skilled qualified electrician must work on the electrical systems.
- If the insulation is damaged, disconnect the power supply immediately and have the insulation repaired.
- Switch off the power supply before you carry out maintenance or cleaning.
- Ensure that live parts do not come into contact with moisture. Moisture can cause a short circuit.

2.5 Risks from rotating parts

Rotating parts

WARNING!

Risk of injury from rotating parts!

Rotating parts in the fan can cause severe injuries.

- Switch off the power supply before you carry out maintenance or cleaning.
- The fan does not stop immediately! Check that no parts are moving once you have opened the ventilation unit.
- Do not reach into the moving fan.
- Do not open the ventilation unit while the fan is in operation.

2.6 Health risk due to hygiene issues

Hygiene issues

⚠ CAUTION!

Health risk due to hygiene issues!

If you do not stick to the maintenance schedule or if the unit is not used for several weeks, bacteria and germs may start growing in the air filter and in the heat recovery unit.

- Change filters and clean the heat recovery unit in the recommended intervals.
- Change the air filters and clean the heat recovery unit after lengthy idle periods.

2.7 Risks caused by an unsuitable installation location

Unsuitable installation location

⚠ WARNING!

Risks caused by an unsuitable installation location!

Installing the unit in an unsuitable location can lead to dangerous situations.

- The ventilation unit should preferably be installed in a thermally insulated, low-leakage building.
- Frost free and dry installation location.
- Install the optional outer casing or use other means (by others) to protect the unit from being tampered with by unauthorised individuals.
- The unit must remain accessible for maintenance and cleaning.

2.8 Qualified staff

Qualification

The work described in this manual has to be carried out by individuals with the qualification, training, knowledge and experience described below:

Facility manager

Facility managers have been instructed so that they are able to avoid any potential hazards related to the work under consideration. Facility managers must not carry out any jobs beyond regular operation unless explicitly stated in this manual and unless the system owner has specifically agreed to them. Instruction is provided by the HVAC contractor when the system is handed over.

Facility managers are responsible for cleaning the unit, for carrying out functional tests and regular checks, for maintenance and for smaller adjustments.

HVAC technician

HVAC technicians are individuals who have sufficient professional or technical training in the field they are working in to enable them to carry out their assigned duties at the level of responsibility allocated to them and in compliance with the relevant guidelines, safety regulations and instructions. HVAC technicians are individuals who have in-depth knowledge and skills related to HVAC systems; they are also responsible for the professional completion of the work under consideration.

HVAC technicians are individuals who have sufficient professional or technical training, knowledge and actual experience to enable them to work on HVAC systems, understand any potential hazards related to the work under consideration, and recognise and avoid any risks involved.

Network administrator

Network administrators design, install, configure and maintain the IT infrastructure in companies or organisations.

Skilled qualified electrician

Skilled qualified electricians are individuals who have sufficient professional or technical training, knowledge and actual experience to enable them to work on electrical systems, understand any potential hazards related to the work under consideration, and recognise and avoid any risks involved.

Any work has to be carried out by individuals who can be expected to carry out their assigned duties reliably. Individuals whose reaction time is delayed due to alcohol, drugs or other medication must not carry out any work.

2.8.1 Personal protective equipment

Personal protective equipment is equipment that protects the user against health or safety risks at work.

Personal protective equipment must be worn for various types of work; the protective equipment required is listed in this manual together with the description of each type of work.

Description of personal protective equipment

Industrial safety helmet



Industrial safety helmets protect the head from falling objects, suspended loads, and the effects of striking the head against stationary objects.

Protective gloves

Protective gloves protect hands from friction, abrasions, punctures, deep cuts, and direct contact with hot surfaces.

Safety shoes

Safety shoes protect the feet from crushing, falling parts and prevent slipping on a slippery floor.

3 Transport and storage

Checking delivered goods

Check delivered items immediately after arrival for transport damage and completeness.

If there is any visible damage, proceed as follows:

- Either do not accept the delivered items, or accept them with reservations.
- Note down the damage on the shipping documents or on the shipping company's delivery note.
- Immediately file a complaint with the shipping company and vendor.



File a complaint as soon as you detect any damage. Claims for compensation can be filed only within the complaint period.

Transport

CAUTION!

Danger of injury from sharp edges, sharp corners and thin sheet metal parts!

Sharp edges, sharp corners and thin sheet metal parts may cause cuts or grazes.

- Be careful when carrying out any work.
- Wear protective gloves, safety shoes and a hard hat.

- If possible, take the unit in its transport packaging up to the installation location.
- Use only lifting and transport gear designed for the required load.
- Always secure the load against tipping and falling.
- Do not move bulky items just by yourself. Get help to prevent injuries and damage.

Storage

Please note:

- Store the product only in its original packaging
- Protect the product from the effects of weather
- Protect the product from humidity, dust and contamination
- Storage temperature: -10 °C to 50 °C.
- Relative humidity: 95% max., no condensation

Packaging

Properly dispose of packaging material.

4 Installation

4.1 General installation information

Before installation

Before you install the unit, take suitable precautions to protect air distribution components from contamination during installation ⇒ VDI 6022.

If this is not possible, at least cover the unit or take other precautions to protect it from contamination. In this case you have to ensure that the unit cannot be started.

Ensure that all components are clean before you install them. If necessary, clean them thoroughly. If you have to interrupt the installation procedure, protect all openings from the ingress of dust or moisture.

Installation information

- Install the ventilation unit preferably in a thermally insulated, low-leakage building.
- Frost free and dry installation location.
- Installation and connections to be performed by others; fixing, connection and sealing material to be provided by others
- Install the unit only on structural elements that can carry the load of the unit.
- Use only certified fixing systems.
- The room facing side of the unit must remain completely accessible for maintenance and cleaning.

Air connection

Two openings in the façade are required, one for outdoor air and one for exhaust air. The ventilation unit is to be sealed to the external wall with a factory fitted closed cell perimeter seal. The surfaces onto which the outdoor air and exhaust air openings are sealed must be even. Ensure that the unit is correctly sealed to the wall.

The outdoor air and exhaust air openings have to be protected against the effects of weather (by others).

4.2 Installing the ventilation unit

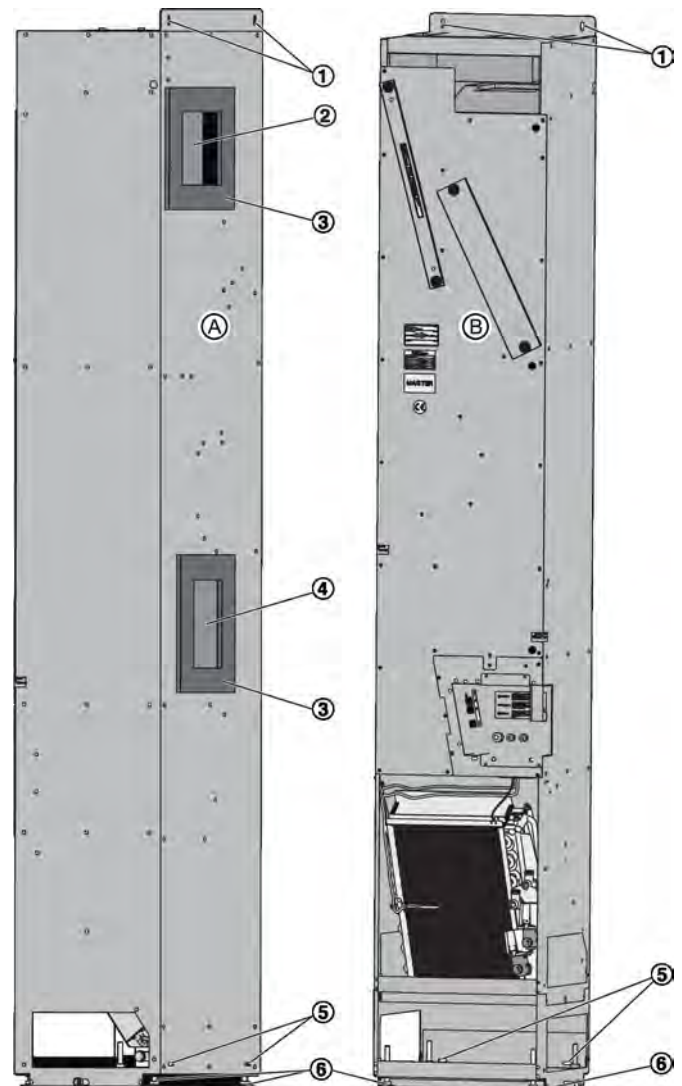

Fig. 8: Installation by example of SCHOOLAIR-V

- Ⓐ Side facing the wall
- Ⓑ Side facing the room
- ① Upper fixing holes
- ② Outdoor air opening
- ③ Seal, 50 x 10 mm (wall side)
- ④ Exhaust air opening
- ⑤ Lower fixing holes
- ⑥ Feet

Dimensions, the position of air openings and the position of fixing points may differ for each variant; drawings with project-specific information are provided together with the order documents.

Personnel:

- HVAC technician

The ventilation unit is to be installed and fixed on the inside of an external wall, vertically, floor-standing. Façade openings for outdoor air and exhaust air are required. Screws and wallplugs for fixing the ventilation unit are not included in the supply package, but have to be selected by others and fit for the wall.

Installing the ventilation unit

Install the unit in such a way that it rests completely on its feet. Use the fixing points only as an additional means of securing the unit against tipping.

Make sure that the unit can be connected to the pipe-work and to the mains supply.

1. ▶ Place the unit in such a way that the wall side (Fig. 8/A) faces the wall. The openings for the air (Fig. 8/2 and Fig. 8/4) must be aligned with the prepared openings in the external wall; adjust the feet if necessary.
2. ▶ Use suitable screws (∅ 6 mm) for the provided fixing holes (Fig. 8/1 and Fig. 8/5) to fix the unit to the external wall.
3. ▶ Adjust the feet, then tighten the nuts.
4. ▶ Protect the ventilation unit with the optional outer casing or with an outer casing provided by others.

The outer casing must prevent unauthorised individuals from reaching into the unit and from being injured (e.g. by electric shock). Make sure that the air can circulate around the unit even with the outer casing.

The interior of the ventilation unit must remain accessible for maintenance.

! NOTICE!

Contamination

If there is a lengthy gap between installation and commissioning of the unit, we recommend the following measures in order to avoid cumbersome cleaning procedures at the time of commissioning.

- Cover all openings of the unit, e.g. with plastic, to prevent the ingress of dust.
- Remove the filters and store them in a dry place, protected from dust; cover the filter openings.
- Switch off the power supply to the unit.

4.3 Connecting the water pipes

Personnel:

- HVAC technician

Protective equipment:

- Industrial safety helmet
- Safety shoes
- Protective gloves

General information

- Using flexible hoses (accessories) instead of rigid water pipes to connect the heat exchanger will make it easier to clean the heat exchanger.
- Fittings such as valves and lockshields are factory fitted but you will have to tighten them at the time of installation.
- Control valves are fitted in the return pipe, lockshields in the flow pipe; this improves the control behaviour.
- Units with a condensate drip tray (optional) require a drainage pipe and a drain trap (by others).
- Control valves, gate valves and safety valves are required; if they are not part of the supply package, they have to be provided by others.
- Drain valves and vent valves are required; if they are not part of the supply package, they have to be provided by others.
- As a last step, check all connections to make sure they do not leak.
- We recommend insulating the pipes in order to prevent energy losses.

! NOTICE!

Temperatures below the dew point

Temperatures below the dew point should be avoided as they lead to condensation which may cause damage to the building structure.

Interfaces	Dimensions	Connection options:
Chilled water/hot water connection	G 1/2" union nut and flat seal, SW24	Screw connection (rigid) Flexible hoses (accessory)
Condensate drain (optional)	Spigot Ø12 mm	Hose (by others)

Marking of 2-pipe heat exchangers

Symbol	Connection	Type of fitting ¹	Operating mode
V (blue)	Chilled water or hot water flow	Lockshield	Cooling or heating ²
R (blue)	Chilled water or hot water return	Control valve	

1) Only units with FSL-CONTROL II.

2) A three-way valve allows for both heating and cooling.

Marking of 4-pipe heat exchangers

Symbol	Connection	Type of fitting ²	Operating mode
V (blue)	Chilled water flow	Lockshield	Cooling
R (blue)	Chilled water return		
V (red)	Hot water flow	Lockshield	Heating
R (red)	Chilled water return	Control valve	

1) Only units with FSL-CONTROL II.

Ensure that the surfaces are clean

1. ▶ Insert seal and tighten screw connection by hand.

! NOTICE!

Heat exchanger and pipes may easily become damaged.

Always use a suitable tool to counter the tightening force in order to prevent any damage.

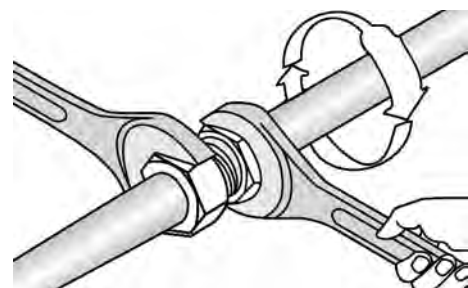

Fig. 9: Tightening the connection

2. ▶ Tighten threaded connections, including valves and lockshields, with a spanner.

! NOTICE!

Subzero temperatures will damage the heat exchanger!

Only fill the heat exchanger if there is no danger of freezing.

3. ▶ Fill the heat exchanger and vent it. To fill the system, use clean tap water (pH value 6.5 to 9) or a water glycol mixture (max. 30 % glycol). Heat exchangers are fitted with bleed screws for venting.
4. ▶ Check the system for leaks immediately after installation and then at regular intervals.

- Ensure that the unit can be de-energised (all phases) for maintenance such that no voltage is present. This requires separators (e.g. fuses or RCBOs); the distance between contacts should be at least 3 mm.
- For units without integral controls from TROX follow the instructions of the controls provider.

Notes on control panels

Select an installation location where the control panel is not affected by disturbances. Avoid solar gain and draughts.

Seal the end of the conduit in the junction box as otherwise a draught could occur in the conduit and affect the measurement results.

4.4 Making electrical connections

! DANGER!

Electric shock hazard! Electrical equipment carries a dangerous electrical voltage!

- Only skilled qualified electricians are allowed to work on the electrical system and to connect the unit to the mains.
- Disconnect the cable from the mains (all phases) and secure the unit against being switched on accidentally.
- Ensure that no voltage is present.
- Carry out assembly or connection jobs only as long as no voltage is present.

Notes on the electrical installation

Use only cables that are designed for the supply voltage for which they will be used. The length and cross section as well as any contact resistance may increase voltage losses. The power rating of each unit must also be considered. A skilled qualified electrician has to select the correct cable types and sizes. This job must only be carried out by specialist electrical companies.

- For the electrical connection comply with any applicable regulations and follow the code of good practice. Be sure to comply with the applicable guidelines for working on electrical and electronic equipment as well as with any applicable local regulations.
- The connection data can be found on the rating plate or in the wiring diagrams.
- Protect any connections from physical damage.
- Feed cables through the cable glands on the ventilation unit.

4.4.1 Wiring

Personnel:

- Skilled qualified electrician

DANGER!

Danger of electric shock! Do not touch any live components! Electrical equipment carries a dangerous electrical voltage.

- Only skilled qualified electricians are allowed to work on the electrical system.
- Switch off the power supply before working on any electrical equipment.

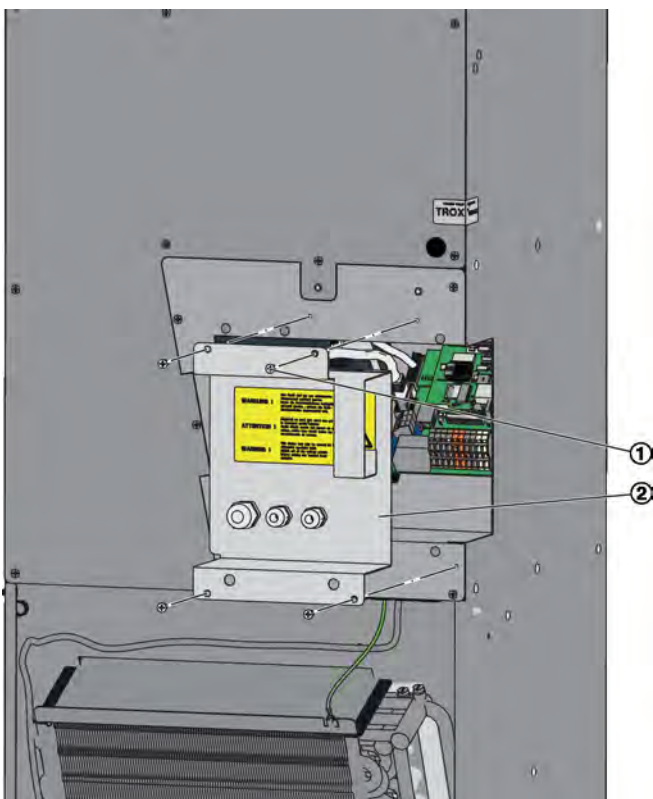

Fig. 10: Electrical connections

1. ▶ Take off the controls access panel (Fig. 10/2); to do so, loosen the Phillips screws (Fig. 10/1), then remove the panel.
2. ▶ Connect the ventilation unit according to the wiring diagram.
 - Stand-alone operation ↗ 22
 - Integration with the central BMS ↗ 25

4.4.1.1 Stand-alone operation

Wiring diagram, unit with digital control panel

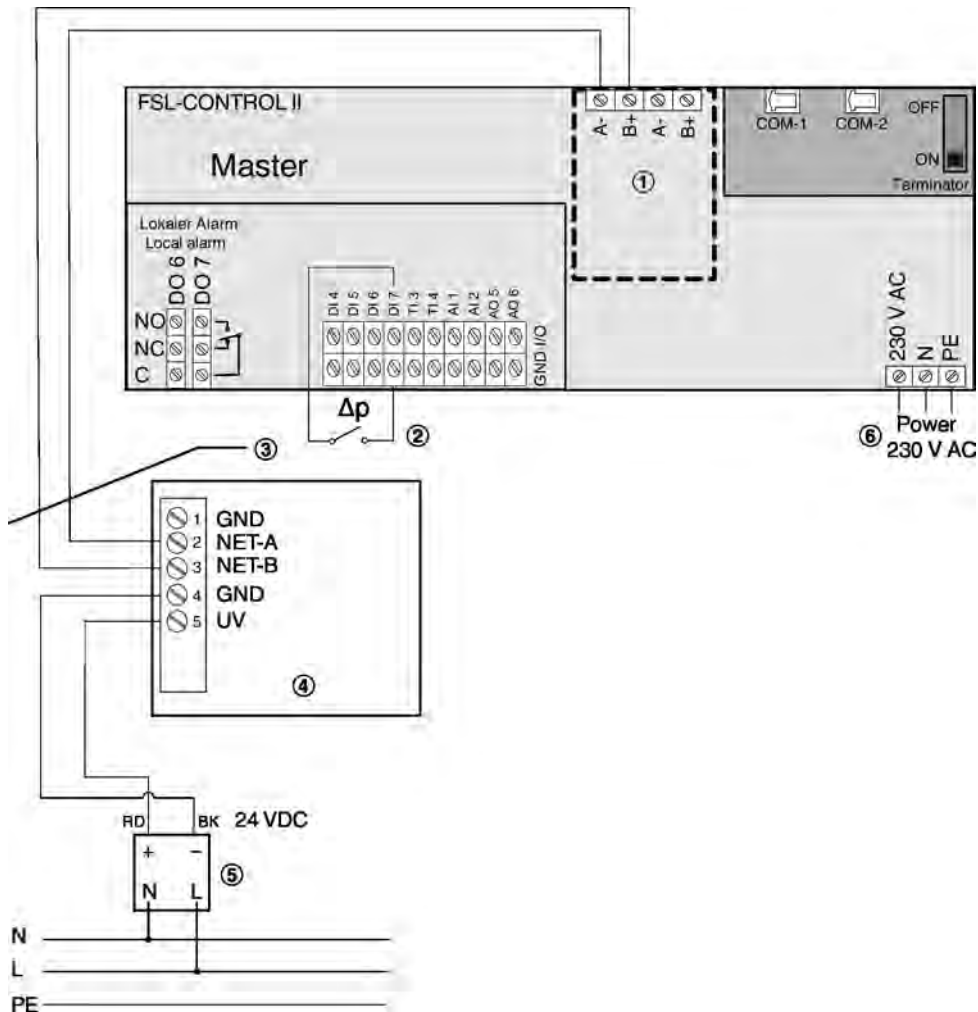

Fig. 11: Wiring diagram, stand-alone operation (without central BMS)

- | | |
|---|---|
| ① LonWorks (FTT10) interface, ⚡ 28 | ④ Digital control panel |
| ② Outdoor air filter differential pressure monitoring, unit variants *-HE, *-HV | ⑤ Power supply unit, 24 V DC (optional or provided by others) |
| ③ JY(St)Y 2 × 2 × 0.8, 10 m max. (use only twisted pair for LON-A and LON-B) | Connecting cable 3 × 0.75 mm ² (L, N, PE) |



Important note:

The digital control panel is a dedicated device to be used with the ventilation unit (master). Both carry the same serial number, which is found on the rating plate (ventilation unit) or on the packaging (control panel).

Use any control panel only for a ventilation unit with the same serial number.

Digital control panel

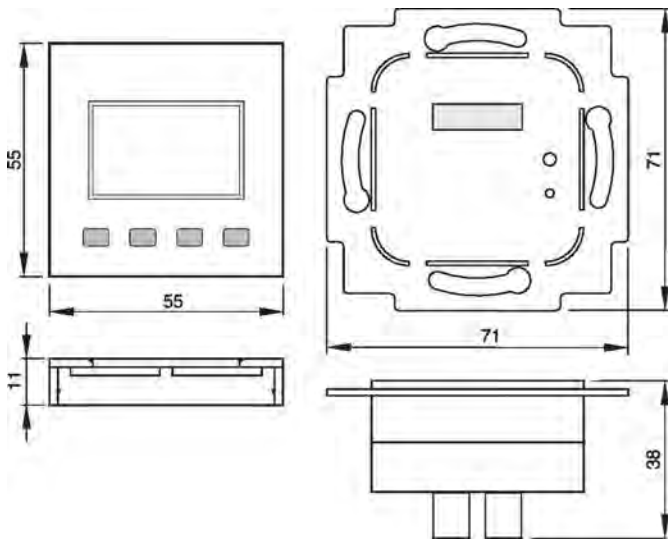

Fig. 12: Dimensions

Note: The overall dimensions depend on the frame that has been selected for the switch.

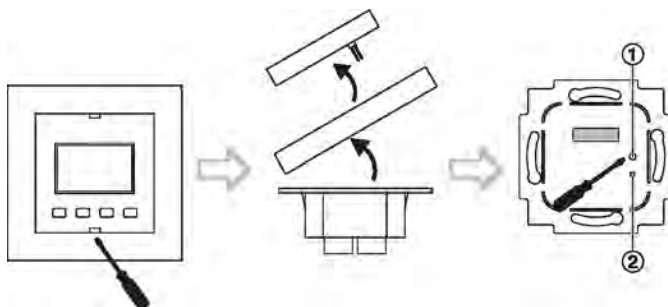

Fig. 13

- 1 Service push button
- 2 Service LED

Notes on installation

The control panel is suitable for installation on a junction box. You can connect the bus cable to the control panel with a screw terminal. For pre-wiring you can remove the screw terminal from the panel.

We recommend using deep junction boxes as they provide more space for cables.

Attach the LON interface card to the screws (by others) in the junction box; max. torque for the screws is 0.8 Nm. Place the mounting ring of the LON interface card flat on the face of the wall; do not cover it with paint or wallpaper.

Technical data

Supply voltage	15...24 V= (±10%) or 24 V~ (±10%)
Power consumption	1.3 W / 1.5 VA
Interface	FTT, free topology
Measuring range	0...+50 °C
Accuracy (21 °C)	±0.5 K
Response time	Time constant t_{63} 15 minutes
Screw terminals	1.5 mm ² max.
Protection level	IP 30 to EN 60529
Ambient temperature	0...50 °C
Transport	-10...50 °C / max. 85% rh, no condensation

Wiring diagram, unit with analogue control panel

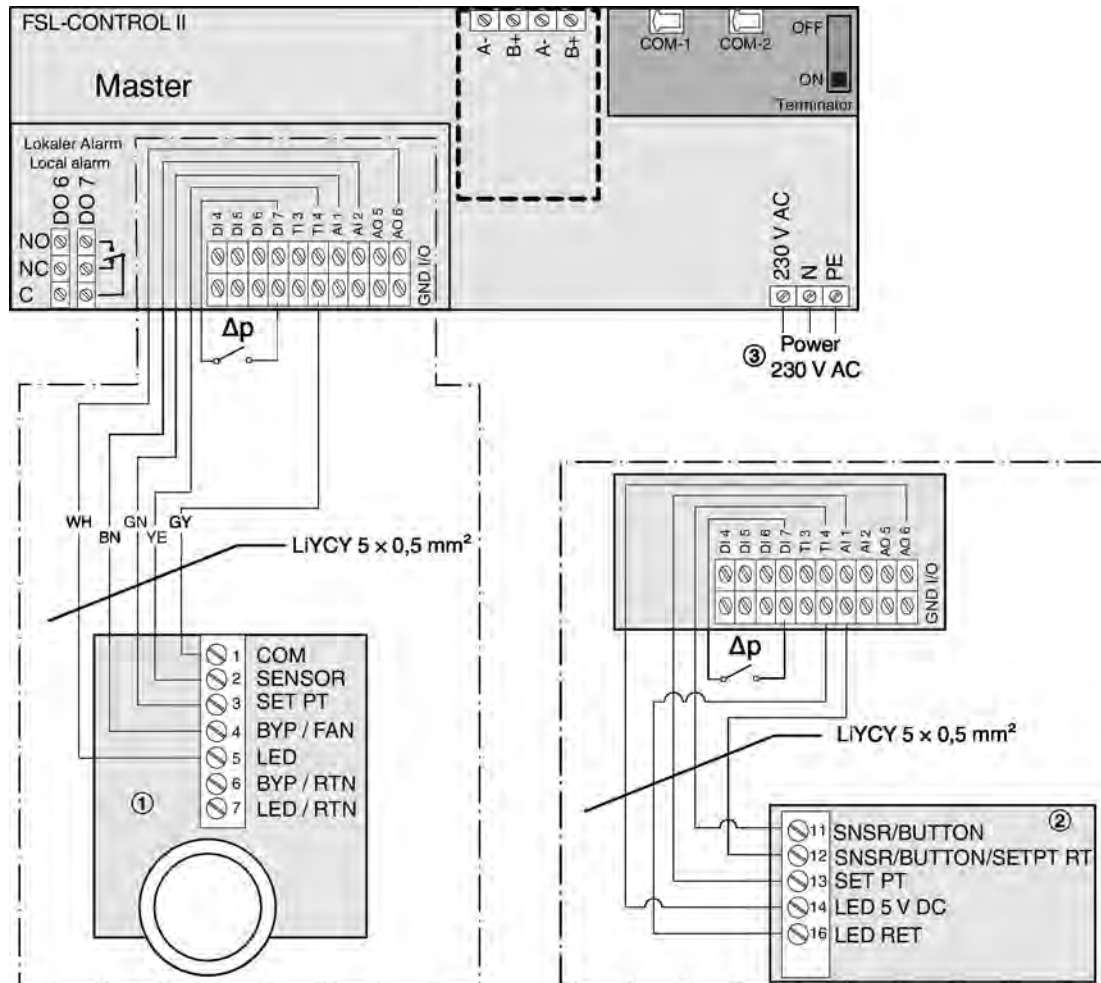

Fig. 14: Wiring diagram for analogue control panels

- ① Control panel with 0-1-2-3-AUTO selector switch
- ② Control panel without selector switch
- ③ Connecting cable 3 x 0.75 mm² (L, N, PE)

4.4.1.2 Integration with a central BMS

Wiring example for three interconnected FSL-CONTROL II controllers in a control zone

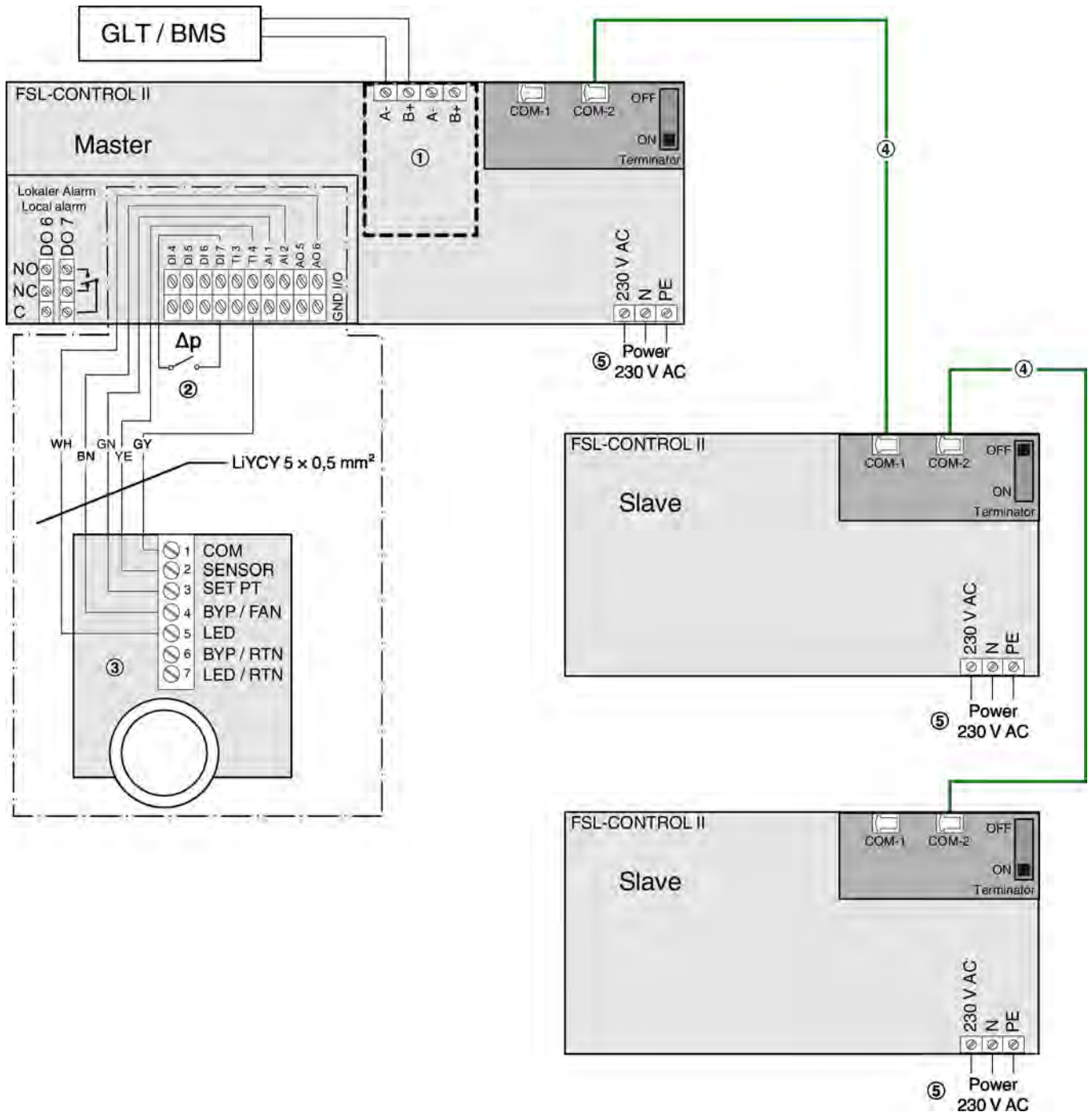

Fig. 15: Wiring diagram: Interconnected FSL-CONTROL II controllers

- ① LonWorks (FTT10) interface or BACnet MS/TP or Modbus RTU interface (optional) ⚡ 27
- ② Outdoor air filter differential pressure monitoring, unit variants *-HE, *-HV
- ③ Analogue control panel with or without selector switch (a digital control panel can be used only for stand-alone operation of the ventilation unit)
- ④ Patch cable (by others, at least cat. 5)
- ⑤ Connecting cable 3 × 0.75 mm² (L, N, PE)

4.4.2 FSL-CONTROL II communication

4.4.2.1 Several controllers in a control zone

Connect FSL-CONTROL II controllers (master-slave) within a control zone with a standard network cable (RJ45, to be provided by others).

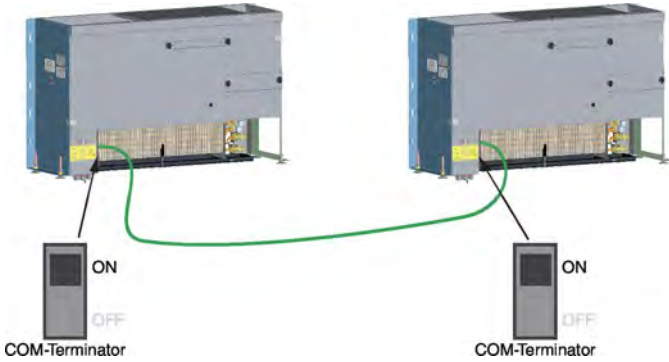

Fig. 16: FSL-CONTROL II communication of 2 units

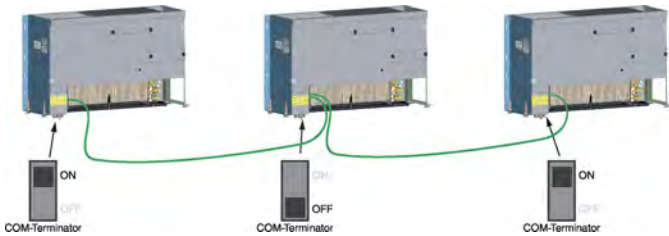

Fig. 17: FSL-CONTROL II communication of 3 units

- Up to 15 FSL-CONTROL II controllers for a control zone (1 × master, 14 × slave)
- Up to 300 m network cable for each control zone
- Network cable type SF-UTP (braided and with foil), to ISO IEC 11801 (2002), as a patch cable with RJ45 plugs on both ends, or from a roll, at least cat. 5
- Activate terminal resistors on the first and last controllers on the communication cable

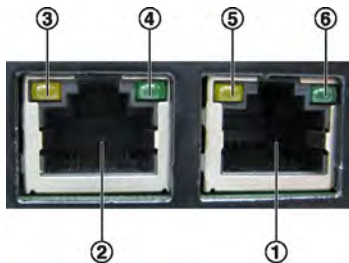

Fig. 18: Sockets and LEDs

- ① Port COM-1
- ② Port COM-2
- ③ LED for communication cable termination
- ④ Not used
- ⑤ LED - Data reception
- ⑥ LED - Heartbeat

LEDs

Termination (yellow)

ON - Cable termination is enabled

OFF - Cable termination is disabled

Data reception (yellow)

ON (blinking) - Data reception in progress

OFF - No data reception

Heartbeat (green)

ON (blinking) - Normal controller operation

OFF - Device not ready

Terminal resistor / termination

Fault-free data exchange between the controllers requires that both ends of the communication cable are terminated.

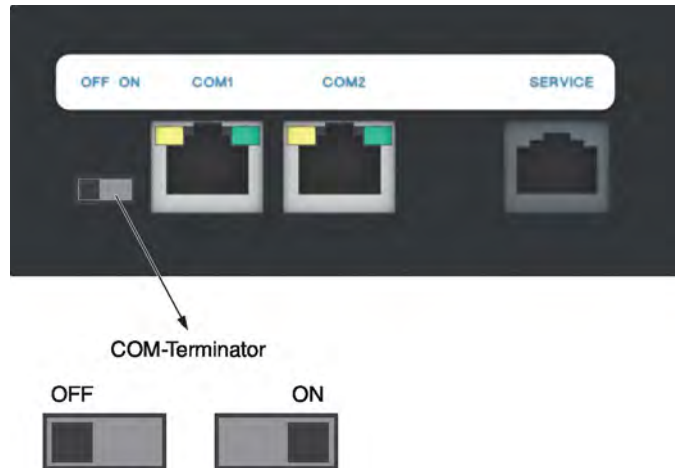

Fig. 19: COM terminal resistor

COM terminal resistor

OFF - Cable termination is disabled

ON - Cable termination is enabled

4.4.2.2 Network with several control zones

Building a network

You may interconnect control zones by making use of a standard network protocol such as LON FTT10, BACnet MS/TP or Modbus RTU. This requires a bus interface card to be connected to the FSL-CONTROL II master controller.

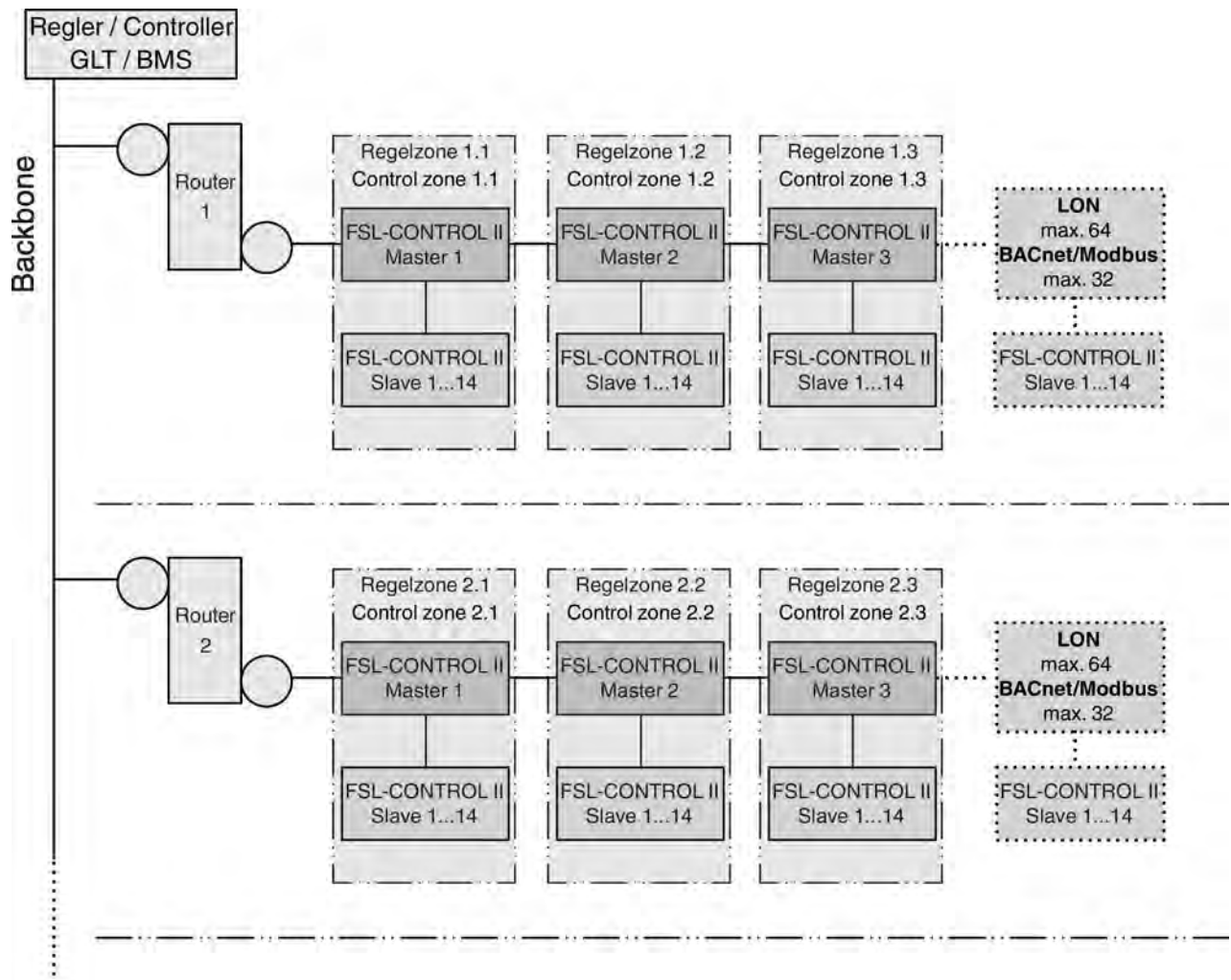

Fig. 20: FSL-CONTROL II, building a network



If the master controller is integrated with a central BMS (by others), it acts as a slave within the bus network, but as a master within the FSL-CONTROL II system.

4.4.2.2.1 Integration with a bus communication system provided by others

LonWorks LON-FTT10 interface module

Connecting data cables

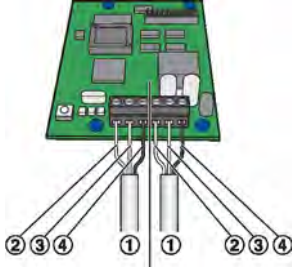

Fig. 21: Wiring the LonWorks interface card

- ① Bus cable
- ② LON A
- ③ LON B
- ④ SH (shield)

The LonWorks interface card has terminals for two bus cables of a LonWorks network. Depending on the network topology, controllers at the end of a chain may be connected to one bus, controllers at other positions in the chain may be connected to two buses.

1. ▶ Strip the insulation from the bus cable (at least two wires), insert the bare wires into the terminals and tighten the screws by hand.
2. ▶ Fix the bus cables to the casing using the wire clamping bracket.
3. ▶ Connect the shield to the SH terminals.

Note: Within a chain (channel) connect the shield only at one point to the earth. Earthing the shield at every controller will lead to voltage disturbances.

4. ▶ To avoid reflections at the end of a chain (channel), use a terminal resistor.

Recommended bus cables

Bus cables to TIA 568A, category 5

- Belden 8471 or 85102
- Cables to DOCSIS specification level IV
- JY(St)Y 2×2×0.8 (use only twisted pair for LON-A and LON-B)

Commissioning

Personnel:

- Network administrator

Materials:

- Software, e.g. Echelon or LonMaker
- Application software, download from www.troxtechnik.com

1. ▶ **Commissioning:** Press the service pin push button and download the application software for the LonWorks node.
2. ▶ **Binding:** Create the logical bindings for the network variables to be transferred by the LonWorks interface card (expansion module). As an alternative, use polling.
3. ▶ **Configuration:** If necessary, adjust the configuration.
4. ▶ Configure data points

BACnet MS/TP or Modbus RTU interface card

Connecting data cables

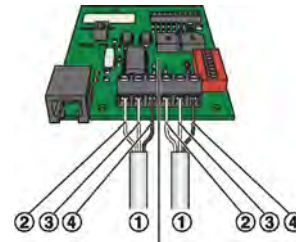

Fig. 22: Wiring the BACnet MS/TP or Modbus RTU interface card

- ① Bus cable
- ② B+ (EIA-485)
- ③ A- (EIA-485)
- ④ SH (shield)

The interface card has terminals for two cables of an EIA-485 network. A maximum of 32 units can be operated on one network segment.

- ▶ Strip the insulation from the bus cable (at least two wires), insert the bare wires into the terminals and tighten the screws by hand.

Make sure that the polarity of the conductor pairs is correct. Incorrect polarity will result in inverted data signals and hence communication errors.

- ▶ Fix the bus cables to the casing using the wire clamping bracket.
- ▶ Connect the shield to the SH terminals.

Note: Within a chain (channel) connect the shield only at one point to the earth. Earthing the shield at every controller will lead to voltage disturbances.

- ▶ To avoid cable reflections, network segments must be terminated at both ends with 120 Ω bus terminal resistors. Alternatively, the terminal resistors can be enabled or disabled on the PCB.

Recommended bus cables

Twisted Pair, e.g. JY(St)Y 2 × 2 × 0.8 (use only twisted pair for B+ and A-)

Hardware configuration

Before you use a BACnet MS/TP or Modbus RTU interface card, you have to configure it to the actual application. To do so, use the switches on the interface card.

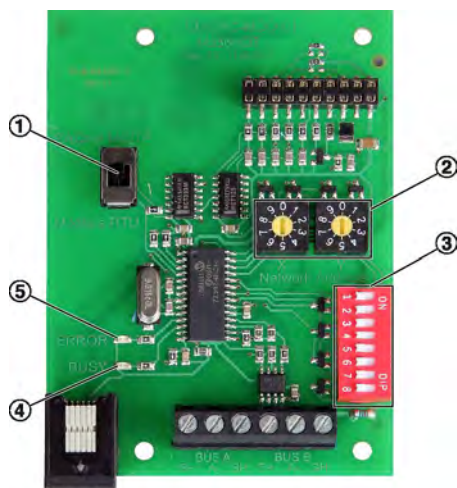

Fig. 23: BACnet MS/TP or Modbus RTU interface card

- ① Slide switch for setting the protocol type
- ② Rotary switch for setting the network address
- ③ DIP switch for setting the communication parameters
- ④ BUSY-LED (green): On = supply voltage OK, blinking = communication in progress
- ⑤ ERROR-LED (red): On = communication error

Setting the protocol type

Use the slide switch (Fig. 23/1) to set the BACnet MS/TP or Modbus RTU protocol.

Setting the network address

Use the two address code switches X and Y (Fig. 23/2) to set a network address (01 to 99). Address 00 is reserved for broadcast mode. A maximum of 32 controllers (network addresses) can be operated on one network segment. Each device requires a different network address.

Transmission speed (EIA-485)

BACnet	Modbus	S2	S3
9600 Bd	9600 Bd	Off	Off
19200 Bd	19200 Bd	On	Off
38400 Bd	38400 Bd	Off	On
76800 Bd	57600 Bd	On	On

Parity

Parity	S5	S6
None	Off	Off
None	On	Off
Odd	Off	On
Even	On	On

Terminal resistor for EIA-485 network

Terminal resistor	S8
Disabled	Off
Enabled	On

Commissioning

Personnel:

- Network administrator
 - ▶ Configuration of data points depending on protocol type
 - BACnet -
 - Modbus RTU -

5 Initial commissioning

Personnel:

- Skilled qualified electrician

Before initial commissioning:

- Remove protective film, if any.
- Ensure that the unit is clean. If necessary, clean the casing and the inlet and outlet openings from dust.
- Professional connection of water pipes:
 - Ensure that all heat exchangers are clean and free from residues and foreign matter.
 - Ensure that the water system including the heat exchanger has been filled and vented.
 - Check operating pressure and temperature; ensure that there are no leaks.
 - If the unit has a condensate drain, check and ensure that the drain does not leak.
- Professional electrical connections:
 - Check and ensure that the actual supply voltage is the same as the one given on the rating plate.
 - Ensure that the ventilation unit has been correctly earthed.
- Check filters for correct fit and contamination
↳ 8.1.1 'Checking and replacing the filters' on page 36. Should the filters have been contaminated even before installation, replace them.

For commissioning see also VDI 6022, part 1 – 'Hygiene requirements for ventilation and air-conditioning systems and units'.

1. ▶ Switch on the power supply.
 - ⇒ The ventilation unit is on.
2. ▶ Configure the control of the ventilation unit, if necessary.

Control of ventilation units

For units with integral FSL-CONTROL II control system

↳ Installation and configuration manual, FSL-CONTROL II single room control.

For units without integral controls from TROX follow the instructions of the controls provider.

6 Control panel settings

6.1 Analogue control panel

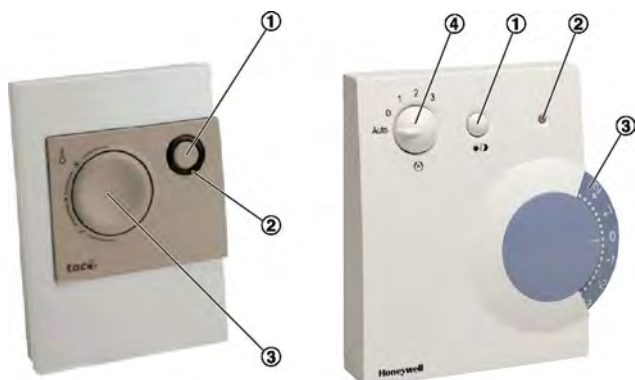

Fig. 24: Control panels

- ① Occupancy push button
- ② LED
- ③ Setpoint value adjuster
- ④ Fan stage selector

Function	Description	LED
Occupied/ Unoccupied ¹	If you want to change the operating mode from 'Occupied' to 'Standby' or vice versa, press the Occupancy push button briefly. This allows you, for example, to manually switch to 'Standby' mode when the room is not occupied. Start-up delay: 1 to 2 minutes in summer, 6 to 7 minutes in winter.	Standby: LED off Occupied: LED on
Boost	If you want to activate or deactivate rapid ventilation of the room, keep the Occupancy push button pressed for some time.	LED blinks slowly
Overtime ¹	If you want to manually switch on the Overtime function while the system is in 'Standby' or 'Unoccupied' mode, press the Occupancy push button briefly. This allows you to set the ventilation unit to 'Occupied' mode for a previously set period of time if, for example, overtime is required after regular office hours. The overtime period can be configured. After the set period the unit resumes the previous operating mode (RTC/central BMS).	Standby: LED off Overtime: LED on
Filter change	Double blinking of the LED indicates that a filter change is required (the number of operating hours can be configured; factory setting: after 2500 h). Units with differential pressure sensor: Activated if the preset maximum differential pressure or the preset number of operating hours is reached. To reset the number of operating hours, either keep the occupancy push button pressed for at least 10 s or use the FSL-CONNECT software.	LED double blinking This function overrides all other LED signals.
Alarm	Frost alarm and hardware alarm.	LED blinks rapidly

1) The room control panel is factory set to either the 'Occupied/Unoccupied' function or the 'Overtime' function. If you need to change this setting, contact the TROX Technical Service.

6.2 Digital control panel

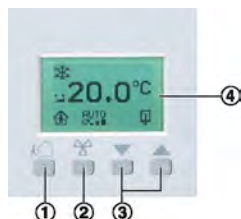

Fig. 25: Digital control panel

Push button Function	Settings	Display ④	Description
① Operating mode	Occupied		The 'Occupied' mode is used for occupied rooms.
	Unoccupied		The 'Unoccupied' mode is used for unoccupied rooms.
	Boost		'Boost' is used to increase ventilation, e.g. during breaks.
② Ventilation	Automatic		Automatic ventilation control.
	Off		Ventilation off.
	Stage 1		Manual ventilation control at the lowest level.
	Stage 2		Manual ventilation control at a medium level.
	Stage 3		Manual ventilation control at the highest level.
③ Temperature	▲		Used to increase the setpoint temperature.
	▼		Used to reduce the setpoint temperature.
Room temperature	–	20.0 °C	Displays the actual room temperature.
Frost protection	–		Indicates that the frost protection function is active, i.e. that the ventilation unit is protected from frost damage at low temperatures.

If you want to change the operating mode between 'Occupied', 'Unoccupied' and 'Boost', press this button briefly.



Start-up time:

- Summer: 1-2 minutes
- Winter 6-7 minutes

You can change the setpoint temperature in increments of 0.5 °C. You can change the default setpoint temperature from -3 °C ... +3 °C.

Example:

- Default setpoint temperature: 21 °C
- Minimum temperature you can set: 18 °C
- Maximum temperature you can set: 24 °C

Push button Function	Settings	Display ④	Description
Filter	–		<p>Indicates that a filter change is due; the number of operating hours after which a filter should be changed can be configured (the factory setting is 2500 h).</p> <p>Units with differential pressure sensor: Activated if the preset maximum differential pressure or the preset number of operating hours is reached.</p> <p>Use the FSL-CONNECT software to reset the counter after a filter change.</p>
Window	–		Indicates that a window is open. The corresponding window contact signal has been received. The ventilation unit is automatically switched off as a consequence.

7 Control of the ventilation unit

Control of ventilation units

For units with integral FSL-CONTROL II control system

↳ Installation and configuration manual, FSL-CONTROL II single room control.

For units without integral controls from TROX follow the instructions of the controls provider.

8 Maintenance and cleaning

DANGER!

Danger of electric shock! Do not touch any live components! Electrical equipment carries a dangerous electrical voltage.

Switch off the supply voltage and secure it against being inadvertently switched on again before working on the unit.

WARNING!

Risk of burning or scalding! The heat exchanger is hot! Before you work on a heat exchanger, switch it off and leave it to cool.

- Carefully clean the heat exchanger with an industrial vacuum cleaner. Be careful to not damage the fins. We recommend using a soft brush with the suction inlet.
- Rinse the heat recovery unit with hot water (40 °C max.), e.g. by using a commercially available shower head.
 - Do not use any organic solvents (such as acetone or methanol) to clean the heat recovery unit.
 - Do not put the heat recovery unit into a dishwasher.

Maintenance

The level of contamination of a ventilation unit depends to a large part on the location of the building and on the length of daily use of the unit.

The system owner should therefore set maintenance intervals based on the hygiene requirements. The legal hygiene requirements have to be met.

An increased dust exposure due to construction work is to be expected during the first three months after initial commissioning; this is why filters should be replaced after three months, and the unit should be cleaned.

We also recommend you to randomly check the contamination level of filters every three months during the first year and use the result as a basis for setting further maintenance intervals.

Operational reliability requires that the necessary maintenance measures are taken in the suggested maintenance intervals, ↪ *'Maintenance measures'* on page 64

Hygiene inspection

A hygiene inspection to VDI 6022 is due every three years. Hygiene inspections have to be carried out by sufficiently qualified individuals and on a random selection of typical ventilation units. If any hygiene issues are detected, all decentralised ventilation units have to be cleaned.

Cleaning

- Cleaning intervals to VDI 6022.
- Clean all surfaces with a damp (not wet) cloth.
- Use only common household cleaners, do not use any caustic, scouring or otherwise aggressive cleaning agents.

8.1 Maintenance

8.1.1 Checking and replacing the filters

Personnel:

- Facility manager

Special tool:

- Commercially available vacuum cleaner

 **CAUTION!****Risk of allergic reaction to filter dust!**

- Wear a dust mask when you change a filter.

As standard, filters have to be changed every 12 months; they have to be changed earlier in the following cases:

- The maximum differential pressure has been reached (only for units with differential pressure sensor).
- The filters have a technical defect or don't meet the required hygiene standard.

Use only original filters. Replacement filters can be ordered from the manufacturer; state the filter material number in your order (see page 2). The material number is given on the filter and in the replacement parts list ↗ 9 'Replacement parts list' on page 41.

1. ▶ **DANGER!**

Danger of electric shock! Do not touch any live components! Electrical equipment carries a dangerous electrical voltage.

- Switch off the power supply before you carry out maintenance or cleaning.
- Only skilled qualified electricians are allowed to work on the electrical system.

Switch off the supply voltage and secure it against being switched on accidentally before cleaning the unit.

- 2. ▶**
- The ventilation unit has been protected by an outer casing (by others). Access to the outer casing has to be provided for any work.

Checking and changing extract air and outdoor air filters

- 3. ▶**
- Depending on the unit variant you may have to remove the inspection access panel or the filter cover, ↗ 1.1 'Variants' on page 5.

Pull out extract air and outdoor air filters.

- 4. ▶**
- Check the filters for damage, contamination and deposits.
-
- 5. ▶**
- Remove contamination in the ventilation unit with a commercially available vacuum cleaner.

- 6. ▶**
- If a filter is intact, free of contamination and deposits, and if it has been used for less than 1 year, put it back into the filter chamber.

If a filter has already been used for a year or if it does no longer meet the technical or hygiene requirements, replace it.



When you insert a new filter, make sure that the labelling at the front of the filter remains visible.

Once inserted, the filter must be flush with the surface as otherwise air will bypass the filter.

- 7. ▶**
- Fix the filter cover or the inspection access panel again (depending on unit variant).
-
- 8. ▶**
- Switch on the power supply.
-
- 9. ▶**
- If the filter operating hours counter in FSL-CONTROL II has been used, reset it after a filter change ↗ Installation and configuration manual FSL CONTROL II.
-
- ⇒ Filter checking or filter change is complete.



Dispose of used filters with residual waste.

8.1.2 Cleaning the heat exchanger and condensate drip tray

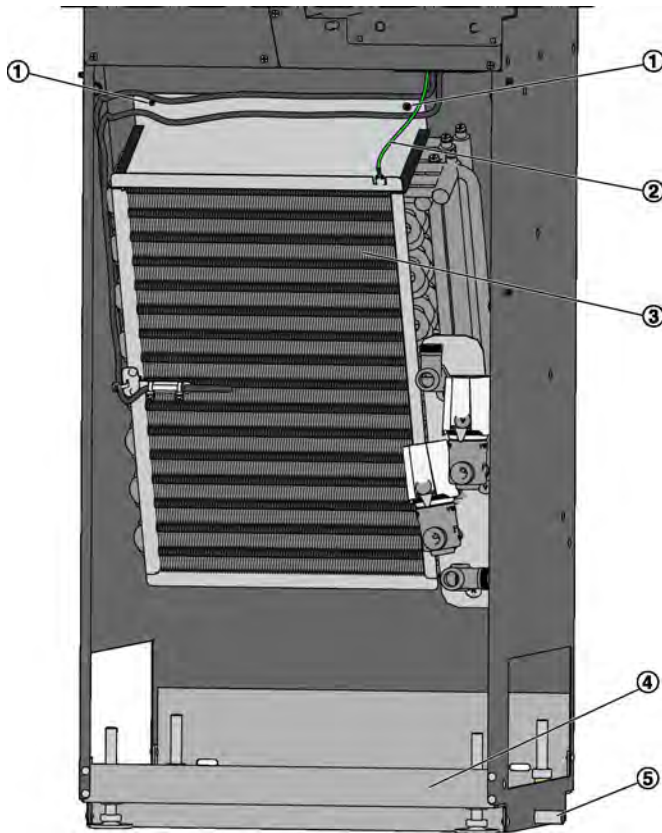

Fig. 26: Heat exchanger (SCHOOLAIR-V shown)

Personnel:

- Facility manager

Special tool:

- Commercially available vacuum cleaner or air compressor

Check the heat exchanger for contamination at least every 12 months. Clean the heat exchanger, if necessary.



Keep the heat exchanger clean as otherwise contamination will impair the efficiency of the ventilation unit.

1. ▶



DANGER!

Danger of electric shock! Do not touch any live components! Electrical equipment carries a dangerous electrical voltage.

- Switch off the power supply before you carry out maintenance or cleaning.
- Only skilled qualified electricians are allowed to work on the electrical system.

Switch off the supply voltage and secure it against being switched on accidentally before working on the unit.

2. ▶ The ventilation unit has been protected by an outer casing (by others). Access to the casing has to be provided for cleaning.

Cleaning the heat exchanger

3. ▶ Depressurise the water-side connections and disconnect the pipes from the heat exchanger.



If you are using flexible hoses (optional), you can clean the heat exchanger without disconnecting the hoses.

Remove the protective earth conductor (Fig. 26/2) from the heat exchanger.

Loosen the two Phillips screws (Fig. 26/1); you can then lift the heat exchanger (Fig. 26/3) out of the unit.

4. ▶ Use a commercially available vacuum cleaner or compressed air to remove contamination from the heat exchanger.

! NOTICE!

Be careful to not damage the fins of the heat exchanger.

5. ▶ Re-install the heat exchanger by following the steps in reverse order.
6. ▶ If necessary, refill the water system (operating pressure) and check for leaks.

Cleaning the condensate drip tray

7. ▶
 - Clean the condensate drip tray (Fig. 26/4) with a commercially available cleaner or disinfectant.
 - Check that the condensate drain (Fig. 26/5) (optional) is not blocked.
8. ▶ Switch on the power supply.
 - ⇒ Cleaning of the heat exchanger and condensate drip tray is complete.

8.1.3 Cleaning the heat recovery unit

Personnel:

- Skilled qualified electrician

Special tool:

- Commercially available vacuum cleaner
- Compressor

1. ▶

DANGER!

Danger of electric shock! Do not touch any live components! Electrical equipment carries a dangerous electrical voltage.

- Switch off the power supply before you carry out maintenance or cleaning.
- Only skilled qualified electricians are allowed to work on the electrical system.

Switch off the supply voltage and secure it against being switched on accidentally before working on the unit.

2. ▶ Depending on the unit variant you may have to remove the inspection access panel or the filter cover ↪ *Opening the cover plate on page 39.*

Variants FSL-V-ZAB / SCHOOLAIR-V / -V-1800 / -V-HE

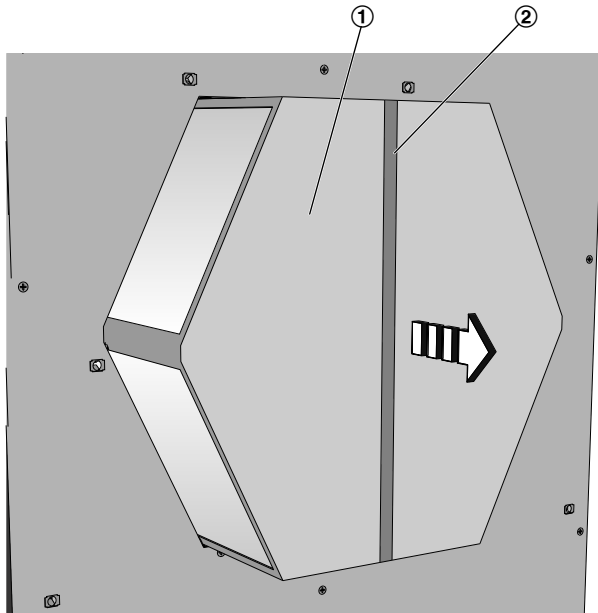

Fig. 27: Removing the heat recovery unit

3. ▶ Grasp the heat recovery unit (Fig. 27/1) by the lug (Fig. 27/2) and pull it out.

NOTICE!

Risk of damage to the heat recovery unit!

Incorrect cleaning may damage the heat recovery unit beyond repair.

- Do not use any organic solvents (such as acetone or methanol) to clean the heat recovery unit.
- Do not put the heat recovery unit into a dishwasher.

Rinse the heat recovery unit (Fig. 27/1) with hot water (40 °C max.), e.g. by using a commercially available shower head.

Put the heat recovery unit into an upright position and let it dry out over night.

SCHOOLAIR-V-HV variants (rotary heat exchanger for heat recovery)

4. ▶ Do not remove the heat recovery unit.

The counter flow function is usually sufficient to keep the heat recovery unit clean. Should this self cleaning not suffice, you may clean the heat recovery unit with compressed air; intervals depend on the degree of contamination.

5. ▶ Remove contamination in the ventilation unit with a commercially available vacuum cleaner.
6. ▶ Place the heat recovery unit onto the rails and push it back into the opening.
7. ▶ Fix the inspection access panel or the unit cover again, ↪ *on page 40.*

NOTICE!

Be sure to insert the protective conductor (Fig. 29/5) when you fix the cover plate.

8. ▶ Switch on the power supply.
- ⇒ The heat recovery unit is clean.

8.1.3.1 Opening the cover plate

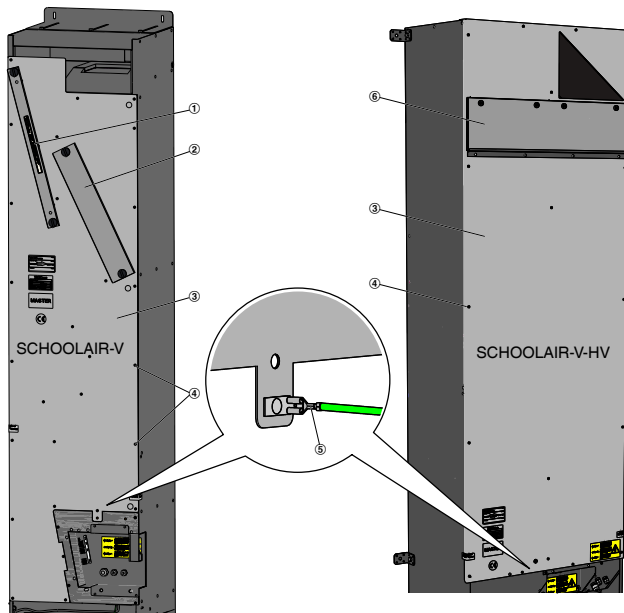

Fig. 28: Removing the cover plate (SCHOOLAIR-V and SCHOOLAIR-V-HV only)

Personnel:

- Facility manager

Preparation

1. ▶



DANGER!

Danger of electric shock! Do not touch any live components! Electrical equipment carries a dangerous electrical voltage.

- Switch off the power supply before you carry out maintenance or cleaning.
- Only skilled qualified electricians are allowed to work on the electrical system.

Switch off the supply voltage and secure it against being switched on accidentally before working on the unit.

- ##### 2. ▶
- The ventilation unit has been protected by an outer casing (by others). Access to the outer casing has to be provided for any work.

SCHOOLAIR-V:

- ##### 3. ▶
- Remove the extract air filter (Fig. 28/1) and remove the cover (Fig. 28/2) from the outdoor air filter chamber ↪ on page 36.

SCHOOLAIR-V-HV:

- ##### 4. ▶
- Remove the inspection access panel (↪ on page 36/6).
- ##### 5. ▶
- Remove the cover plate (Fig. 28/3) by loosening all the Phillips screws (Fig. 28/4) on the plate.

Disconnect the protective conductor (Fig. 28/5) when you remove the plate.

⇒ The cover plate has been removed.

! NOTICE!

Risk of damage due to incorrect handling

Be careful to not damage the glass fibre fabric or the insulation when you clean or maintain the unit after the cover plate has been opened or removed.

8.1.3.2 Closing the cover plate

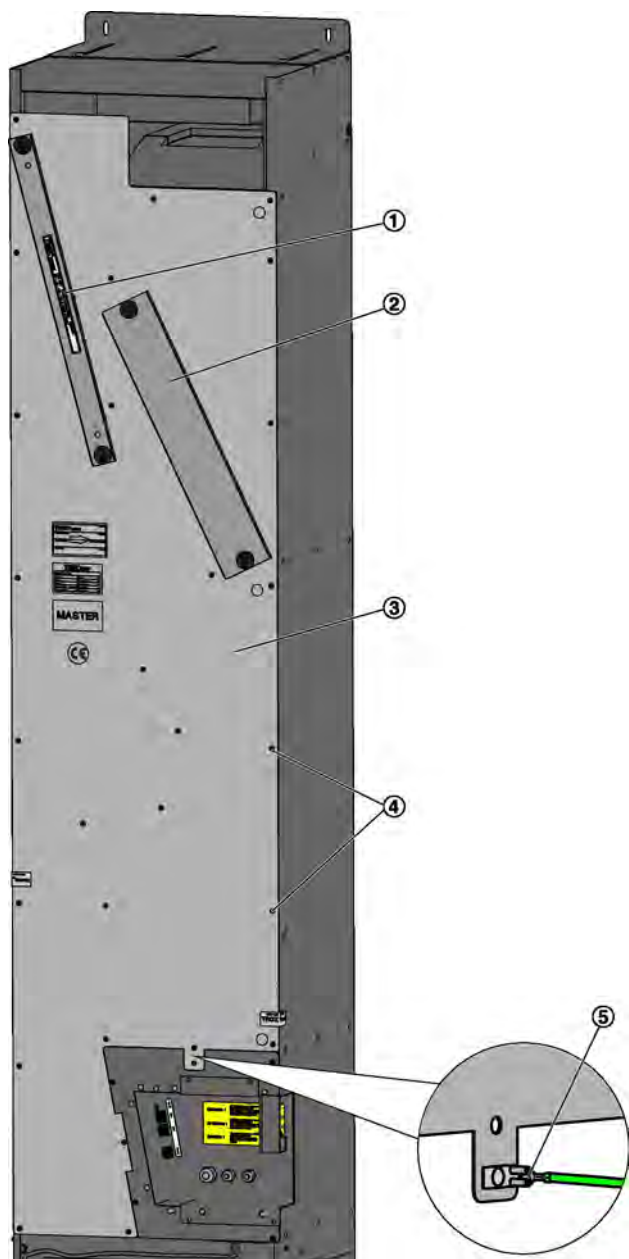

Fig. 29: Fixing the cover plate

Personnel:

- Facility manager

Maintenance is complete and all parts have been correctly replaced.

1. ▶ Attach the protective earth conductor (Fig. 29/5) to the cover plate, then put the panel back onto the ventilation unit (Fig. 29/3). Fix the cover plate with the Phillips screws (Fig. 29/4).
2. ▶ Insert the extract air filter (Fig. 29/1) (Fig. 29/2) and remove the cover from the outdoor air filter chamber Fig. 29.
3. ▶ Switch on the power supply.
 - ⇒ The cover plate has been fixed and the power supply has been switched on.

9 Replacement parts list

FSL-V-ZAB/SEK	-	↳	42
SCHOOLAIR-V	-	↳	44
SCHOOLAIR-V-1800	-	↳	46
SCHOOLAIR-V-HE	-	↳	48
SCHOOLAIR-V-HV	-	↳	50

FSL-V-ZAB/SEK

9.1 FSL-V-ZAB/SEK

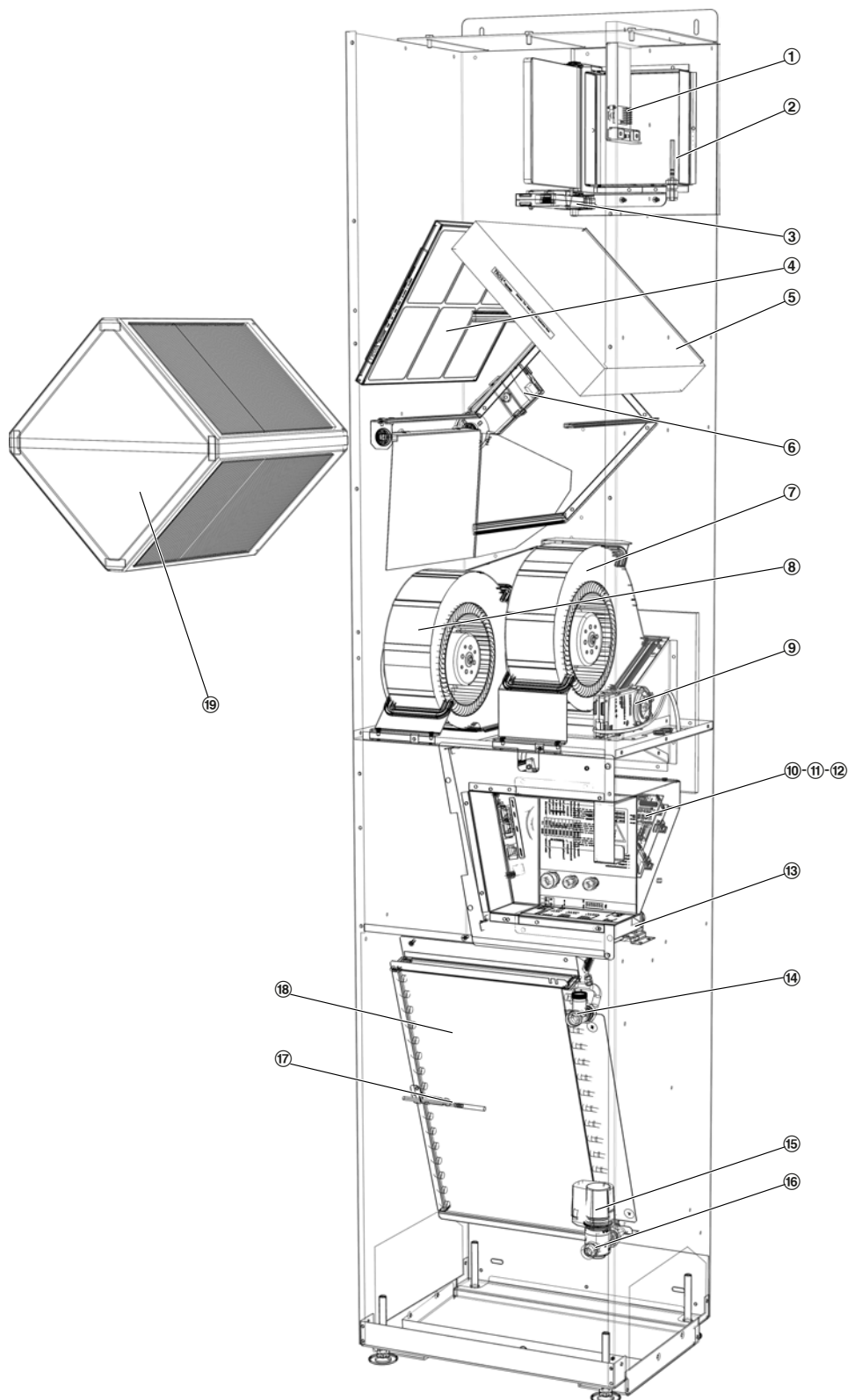

Fig. 30: FSL-V-ZAB/SEK replacement parts; illustration shows the ventilation unit with the heat recovery unit removed

**Ordering replacement parts**

You can identify order-specific components of the ventilation unit either by a code on the component itself or by the commission number on the rating plate ↗ 'Rating plate' on page 53. TROX Service: ↗ 'TROX Technical Service' on page 3

Item	Description	Replacement part no.
1	VOC sensor	M546GA7
2	Outdoor air temperature sensor	M546EI5
3	Actuator for outdoor air damper	M466EQ6
4	G3 extract air filter ↗ 36	FMP-G3-C17/PADx239x305
5	F7 outdoor air filter ↗ 36	FP-F7-NWO/252x306x50/STR
6	Actuator for bypass damper	A00000018566
7	Extract air centrifugal fan	M546FG0
8	Supply air centrifugal fan	M546FG0
9	Actuator for exhaust air damper	M466EQ6
10	FSL-CONTROL II control module	M536ED8
11	FSL-CONTROL II master module	M536ED9
12	RTC (real-time clock) expansion module	M536EE0
13	SKM module for controlling the outdoor air dampers	M536ED0
14	Lockshield	M431AQ4
15	Valve actuator FSL-CONTROL II	Order-specific
16	Straight-way valve	Order-specific
17	Supply air temperature sensor	M546EI5
18	2-pipe or 4-pipe heat exchanger ↗ 37	See no. on the heat exchanger
19	Heat recovery unit	A00000052316

9.2 SCHOOLAIR-V

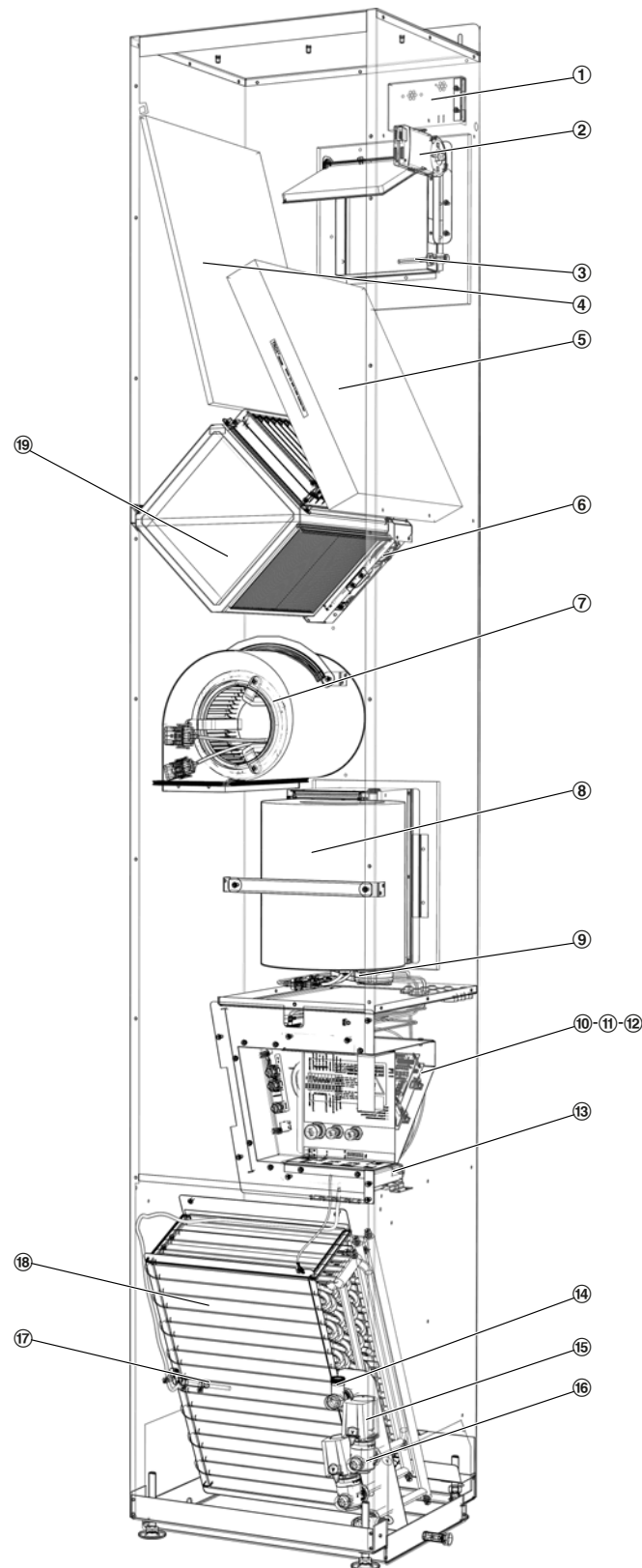

Fig. 31: SCHOOLAIR-V replacement parts

**Ordering replacement parts**

You can identify order-specific components of the ventilation unit either by a code on the component itself or by the commission number on the rating plate ↗ 'Rating plate' on page 53. TROX Service: ↗ 'TROX Technical Service' on page 3

Item	Description	Replacement part no.
1	VOC sensor	M546GA7
2	Actuator for outdoor air damper	M466EQ6
3	Outdoor air temperature sensor	M546EI5
4	G3 extract air filter ↗ 36	FMP-G3-C17/PADx429x345
5	F7 outdoor air filter ↗ 36	FP-F7-NWO/370x348x50/STR
6	Actuator for bypass damper	A00000018566
7	Supply air centrifugal fan	M546FG0
8	Extract air centrifugal fan	M546FG0
9	Actuator for exhaust air damper	M466EQ6
10	FSL-CONTROL II control module	M536ED8
11	FSL-CONTROL II master module	M536ED9
12	RTC (real-time clock) expansion module	M536EE0
13	SKM module for controlling the outdoor air dampers	M536ED0
14	Lockshield	M431AQ4
15	Valve actuator FSL-CONTROL II	Order-specific
16	Straight-way valve	Order-specific
17	Supply air temperature sensor	M546EI5
18	2-pipe or 4-pipe heat exchanger	See no. on the heat exchanger
19	Heat recovery unit	M432KG0

9.3 SCHOOLAIR-V-1800

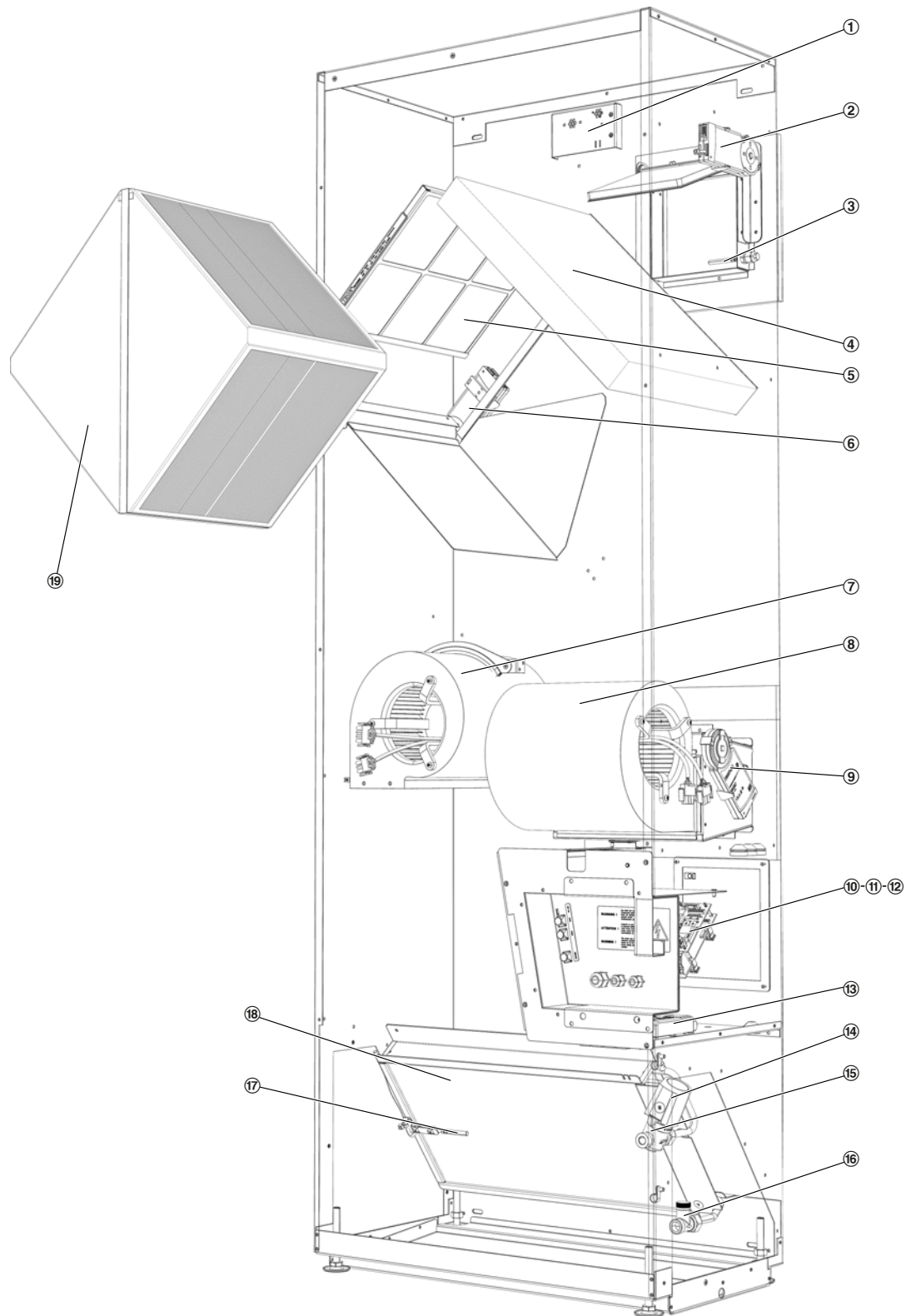

Fig. 32: SCHOOLAIR-V-1800 replacement parts

**Ordering replacement parts**

You can identify order-specific components of the ventilation unit either by a code on the component itself or by the commission number on the rating plate ↗ 'Rating plate' on page 53. TROX Service: ↗ 'TROX Technical Service' on page 3

Item	Description	Replacement part no.
1	VOC sensor	M546GA7
2	Actuator for outdoor air damper	M466EQ6
3	Outdoor air temperature sensor	M546EI5
4	F7 outdoor air filter ↗ 36	FP-F7-NWO/421x346x50/STR
5	G3 extract air filter ↗ 36	FMP-G3-C17/PADx264x345
6	Actuator for bypass damper	A00000018566
7	Supply air centrifugal fan	M546FG0
8	Extract air centrifugal fan	M546FG0
9	Actuator for exhaust air damper	M466EQ6
10	FSL-CONTROL II control module	M536ED8
11	FSL-CONTROL II master module	M536ED9
12	RTC (real-time clock) expansion module	M536EE0
13	SKM module for controlling the outdoor air dampers	M536ED0
14	Valve actuator FSL-CONTROL II	Order-specific
15	Straight-way valve	Order-specific
16	Lockshield	M431AQ4
17	Supply air temperature sensor	M546EI5
18	2-pipe or 4-pipe heat exchanger	See no. on the heat exchanger
19	Heat recovery unit	A00000045740

9.4 SCHOOLAIR-V-HE

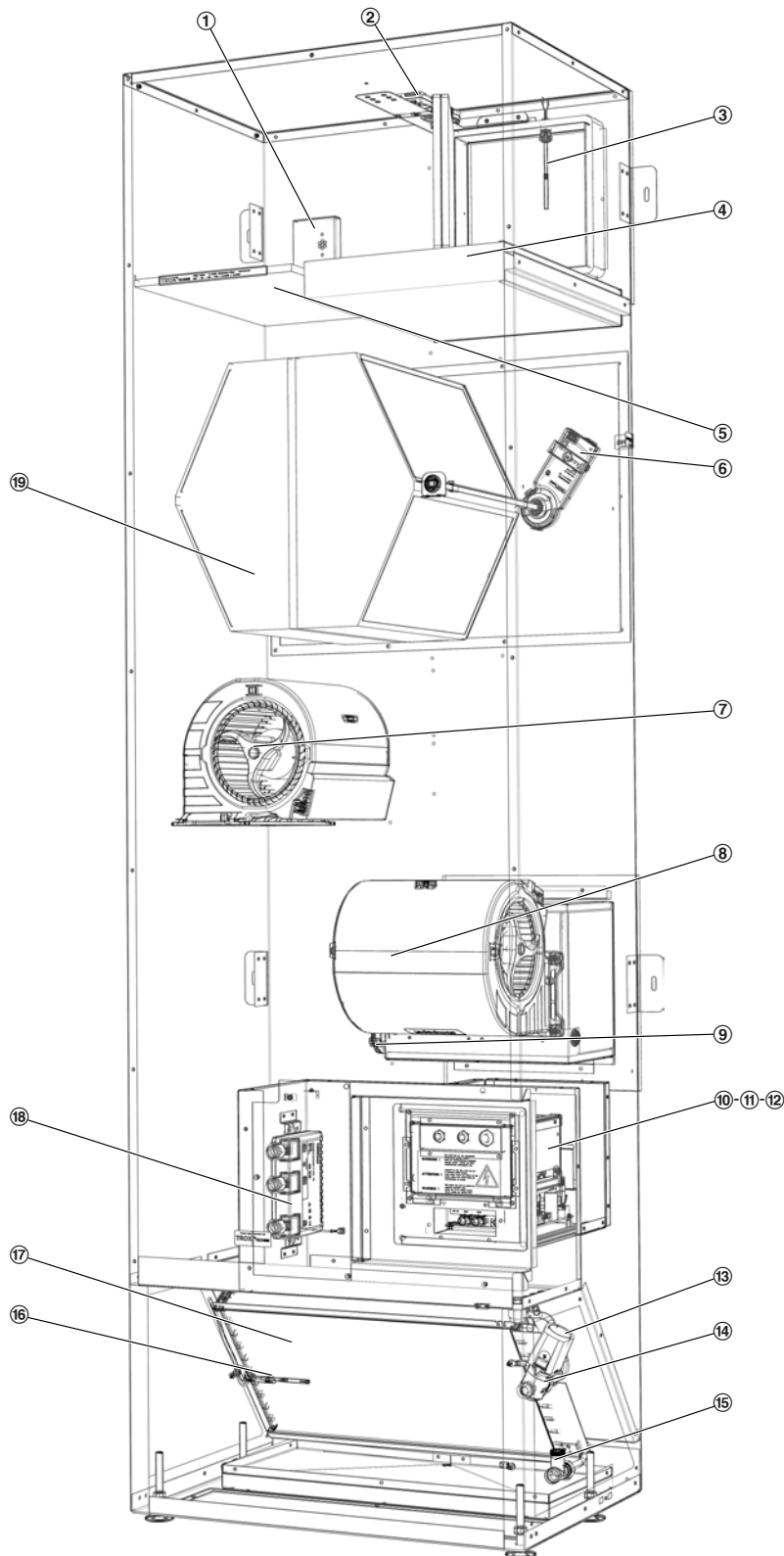

Fig. 33: SCHOOLAIR-V-HE replacement parts

**Ordering replacement parts**

You can identify order-specific components of the ventilation unit either by a code on the component itself or by the commission number on the rating plate ↗ 'Rating plate' on page 53. TROX Service: ↗ 'TROX Technical Service' on page 3

Item	Description	Replacement part no.
1	VOC sensor	M546GA7
2	Actuator for outdoor air damper	M466EQ6
3	Outdoor air temperature sensor	M546EI5
4	F7 outdoor air filter ↗ 36	FP-F7-NWO/295x394x50/STR
5	G3 extract air filter ↗ 36	FMP-G3-C17/PADx247x362
6	Actuator for bypass damper	A00000018566
7	Supply air centrifugal fan	A00000036047
8	Extract air centrifugal fan	A00000036047
9	Actuator for exhaust air damper	M466EQ6
10	FSL-CONTROL II control module	M536ED8
11	FSL-CONTROL II master module	M536ED9
12	RTC (real-time clock) expansion module	M536EE0
13	Valve actuator FSL-CONTROL II	Order-specific
14	Straight-way valve	Order-specific
15	Lockshield	M431AQ4
16	Supply air temperature sensor	M546EI5
17	2-pipe or 4-pipe heat exchanger	See no. on the heat exchanger
18	SKM module for controlling the outdoor air dampers	M536ED0
19	Heat recovery unit	A00000056156

9.5 SCHOOLAIR-V-HV

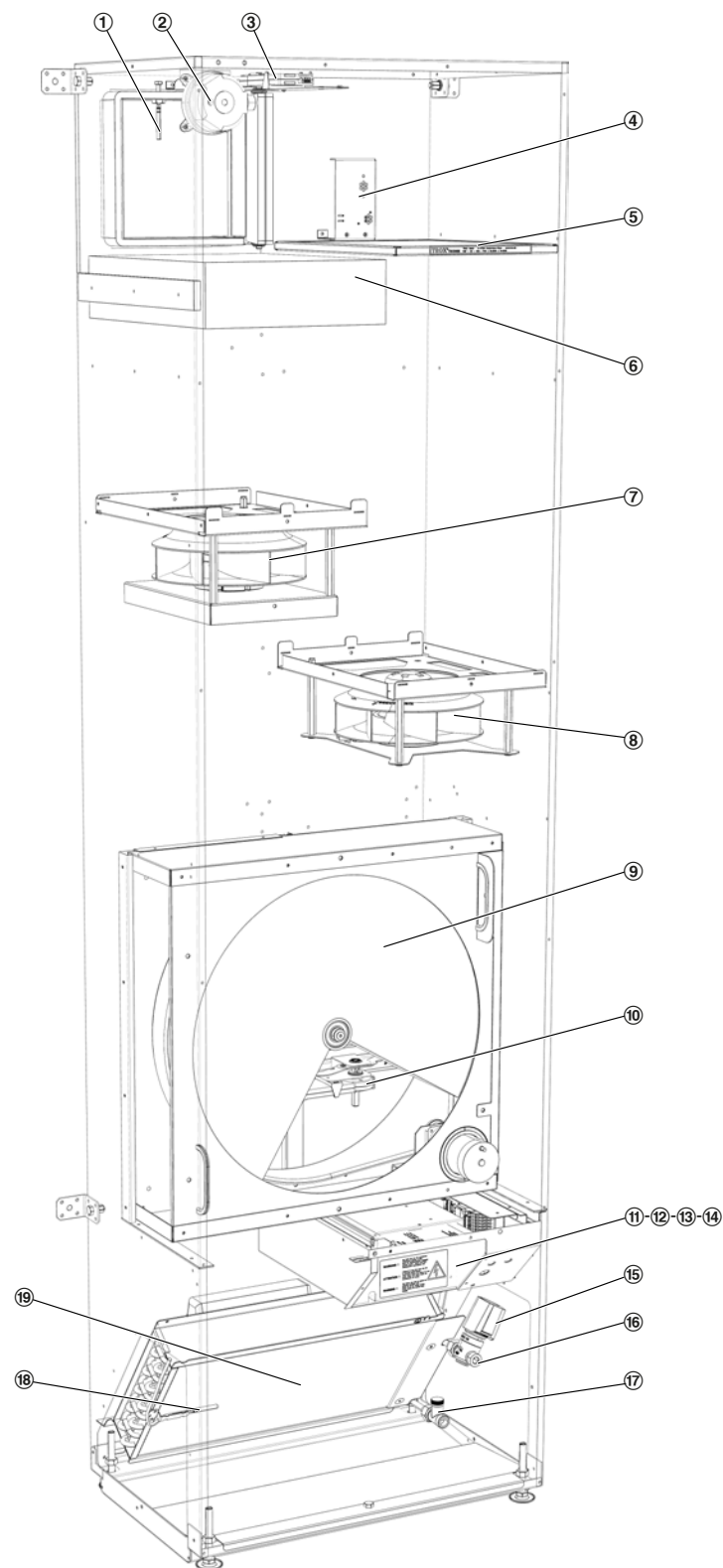

Fig. 34: SCHOOLAIR-V-HV replacement parts

**Ordering replacement parts**

You can identify order-specific components of the ventilation unit either by a code on the component itself or by the commission number on the rating plate ↗ 'Rating plate' on page 53. TROX Service: ↗ 'TROX Technical Service' on page 3

Item	Description	Replacement part no.
1	Outdoor air temperature sensor	M546EI5
2	Differential pressure sensor	A00000064140
3	Actuator for outdoor air damper	M466EQ6
4	VOC sensor	M546GA7
5	G3 extract air filter ↗ 36	FMP-G3-C17/PADx265x361
6	F7 outdoor air filter ↗ 36	FP-F7-NWO/385x380x90/STR
7	Supply air centrifugal fan	M546FG0
8	Extract air centrifugal fan	M546FG0
9	Rotary heat exchanger for heat recovery	A00000062896
10	Actuator for exhaust air damper	M466EQ6
11	FSL-CONTROL II control module	M536ED8
12	FSL-CONTROL II master module	M536ED9
13	RTC (real-time clock) expansion module	M536EE0
14	SKM module for controlling the outdoor air dampers	M536ED0
15	Valve actuator FSL-CONTROL II	Order-specific
16	Straight-way valve	Order-specific
17	Lockshield	M431AQ4
18	Supply air temperature sensor	M546EI5
19	2-pipe or 4-pipe heat exchanger	See no. on the heat exchanger

10 Technical data

10.1 Technical data

Technical data sheets

An illustration and the technical data have already been provided for information and acceptance by the customer. We recommend that you keep those documents with this manual.

Item	Unit	FSL	SCHOOLAIR				
		-V-ZAB/SEK	-V-2L	V-4L	-V-1800	-V-HE	-V-HV
Max. operating pressure, water side	bar	6					
Max. operating temperature	°C	75					
Max. operating temperature with flexible connecting hoses	°C	55					
Supply voltage	V AC	230 ±10%					
Supply voltage, frequency	Hz	50/60					
Protection level	IP	21					
Width	mm	400	397		600		
Height	mm	1800	2160	2350	1800	2000	2200
Depth	mm	320	359			408	
Volume flow rate	m³/h	60-150	150-320		150-350	150-360	250-600
Total heating capacity ¹⁾	W	2460	5470	5760	5630	6020	4780
Heating capacity per room	W	471	1422	1680	1005	900	3300
Total cooling capacity ²⁾	W	688	–	1440	1590	1685	1750
Cooling capacity per room	W	408	–	850	935	965	1470
Heat recovery efficiency	%	52	46		54	84	75
Power consumption (nominal volume flow rate)	W	27	44	45	46	42	147
Rating	VA	185	174	176	185	510	595
Weight	kg	80	85	87	85	90	145

1) Sizing data: Standard outdoor air temperature, supply air temperature: 40 °C, max. volume flow rate

2) Sizing data: Standard outdoor air temperature, supply air temperature: 18 °C, max. volume flow rate

Rating plate

Geräte-Typ:	
Herstelljahr:	Schutzart:
Kom.-Nr.:	max. Wassertemperatur:
Serien-Nr.:	max. Betriebsdruck:
Versorgungsspannung:	Filterklasse Zuluft:
max. Leistungsaufnahme:	Filterklasse Abluft:

Fig. 35: The rating plate is affixed to the cover plate.

- ① Type of unit
- ② Year of manufacture
- ③ Commissioning no.
- ④ Serial number
- ⑤ Supply voltage
- ⑥ Max. power consumption
- ⑦ Protection level
- ⑧ Max. water temperature
- ⑨ Max. operating pressure
- ⑩ Supply air filter class
- ⑪ Extract air filter class

11 Index**B**

BACnet MS/TP interface..... 28

C

Checking delivered goods..... 16

Cleaning..... 35

Condensate drip tray

Cleaning..... 37

Control

By others..... 30, 34

FSL-CONTROL II..... 30, 34

Control panel..... 20

Copyright..... 3

Correct use..... 12

Cover

Fixing..... 40

Removing..... 39

Cover plate

Fixing..... 40

Removing..... 39

D

Defects liability..... 3

E

Electrical installation..... 20

Extract air filter

Checking..... 36

Replacing..... 36

F

Filter change..... 36

Filters

Checking..... 36

Replacing..... 36

FSL-CONTROL II

Control..... 30, 34

H

Heat exchanger

Cleaning..... 37

Heat recovery unit

Cleaning..... 38

Hotline..... 3

Hygiene inspection..... 35

I

Incorrect use..... 13

L

Limitation of liability..... 3

LonWorks interface module..... 28

M

Maintenance..... 35

Modbus RTU interface..... 28

O

Outdoor air filter

Checking..... 36

Replacing..... 36

P

Packaging..... 16

Personnel..... 14

Protective equipment..... 14

Q

Qualification..... 14

S

Service..... 3

Signs..... 13

Symbols..... 12

T

Technical service..... 3

Appendix

EU declaration of conformity

EC/EU Declaration of Conformity

**Manufacturer**

TROX GmbH
Heinrich-Trox-Platz
47504 Neukirchen-Vluyn,
Germany

Person who is authorised to compile the technical file and is established in the Community

Jan Heymann, TROX GmbH

Description and identification of the machinery

Product / Product type	Decentralised ventilation units FSL-V-ZAB/SEK; SCHOOLAIR-V / -V-1800 / -V-HE / -V-HV
Function	Vertical under sill units with FSL Control II Decentralised ventilation units are used to create a comfortable room temperature and to ventilate rooms such as offices, meeting rooms, or classrooms in schools.

We declare that the above mentioned product fulfils all the relevant provisions of the following EC/EU Directives:

2006/42/EC	Directive 2006/42/EC of the European Parliament and of the Council of 17 May 2006 on machinery, and amending Directive 95/16/EC (recast) (1)
2014/30/EU	Directive 2014/30/EU of the European Parliament and of the Council of 26 February 2014 on the harmonisation of the laws of the Member States relating to electromagnetic compatibility (recast)
2014/35/EU	Directive 2014/35/EU of the European Parliament and of the Council of 26 February 2014 on the harmonisation of the laws of the Member States relating to the making available on the market of electrical equipment designed for use within certain voltage limits

Applied harmonised standards:

EN 349:1993+A1	Safety of machines - Minimum gaps to avoid crushing of parts of the human body safety of
EN 1037:1995+A1	machines - Avoidance of unexpected start-up
EN 60204-1:2006/A1	Safety of machinery - Electrical equipment of machines - Part 1: General requirements (IEC 60204-1:2005)
EN 547-2:1996+A1	Safety of machinery - Human body measurements - Part 2: Principles for determining the dimensions required for access openings
EN 1005-3:2002+A1	Safety of machinery - Human physical performance - Part 3: Recommended force limits for machinery operation
EN ISO 13857:2008	Safety of machinery - Safety distances to prevent hazard zones being reached by upper and lower limbs (ISO 13857:2008)
EN 547-3:1996+A1	Safety of machinery - Human body measurements - Part 3: Anthropometric data
EN 1005-2:2003+A1	Safety of machinery - Human physical performance - Part 2: Manual handling of machinery and component parts of machinery
EN 1005-1:2001+A1	Safety of machinery - Human physical performance - Part 1: Terms and definitions
EN ISO 13732-1:2008	Ergonomics of the thermal environment - Methods for the assessment of human responses to contact with surfaces - Part 1: Hot surfaces (ISO 13732-1:2008)
EN ISO 12100:2010-11	Safety of machinery - General principles for design - Risk assessment and risk reduction (ISO 12100:2010)

Neukirchen-Vluyn, 4 October 2017

Jan Heymann
Authorised representative, CE-marked products, TROX GmbH

Page 1/1

Product information according to ErP directive

FSL-V-ZAB/SEK

Product information





The art of handling air

a) Manufacturer's name	TROX GmbH Heinrich-Trox-Platz 47504 Neukirchen-Vluyn, Germany	Phone +49 (0)2845 2020 Fax +49 (0)2845 202265 E-mail trox@trox.de Internet www.troxtechnik.com
b) Model identifier	V-ZAB/SEK-2L-398x1800x318 V-ZAB/SEK-4L-398x1800x318	

Product information with regard to residential ventilation units according to Regulation (EU) No 1254/2014, Article 3 (1)

	Information requirement	Technical data for the supplied product
c)	Specific energy consumption (SEC)	
	Cold	-66,60 kWh/(m ² × a)
	Average	-35,77 kWh/(m² × a) ⇒ Energy efficiency class A
	Warm	-15,47 kWh/(m ² × a)
d)	Type	Bidirectional
e)	Type of drive installed	Multi-speed drive
f)	Heat recovery system (HRS)	Recuperative
g)	Thermal efficiency of HRS	51 %
h)	Maximum flow rate (\dot{V}_{max})	150 m ³ /h
i)	Electric power input at maximum flow rate \dot{V}_{max}	29 Watt
j)	Sound power level L_{WA} at \dot{V}_{Rfr}	36 dB(A)
k)	Reference flow rate (\dot{V}_{Rfr})	105 m ³ /h
l)	Reference pressure difference	0 Pa
m)	Specific power input (SPI) at \dot{V}_{max}	0,113 W/(m ³ /h)
n)	Control factor	Local demand control
	Control typology	Non-ducted ventilation units
o)	Internal leakage rate at (\dot{V}_{Rfr}) and 100 Pa	8 %
	External leakage rate at (\dot{V}_{Rfr}) and 100 Pa	4 %
p)	Mixing rate	< 2 %
q)	Filter warning ①	On the control panel - (LED double blinking)
s)	Disassembly instructions	www.trox.de
t)	Airflow sensitivity to pressure variations at \dot{V}_{max} and +20 Pa	+3 %
	Airflow sensitivity to pressure variations at \dot{V}_{max} and -20 Pa	- 3 %
u)	Indoor/outdoor air tightness	0 m ³ /h
v)	Annual electricity consumption (AEC)	1,11 kWh/(m ² × a)
w)	Annual heating energy saving (AHS)	
	Cold	74,07 kWh/(m ² × a)
	Average	37,86 kWh/(m ² × a)
	Warm	17,12 kWh/(m ² × a)

 ① Filters have to be changed regularly! This will increase the energy efficiency of the unit, reduce the electricity consumption of the fans and protect our environment in the long term.

FSL-V-ZAB/SEK energy label

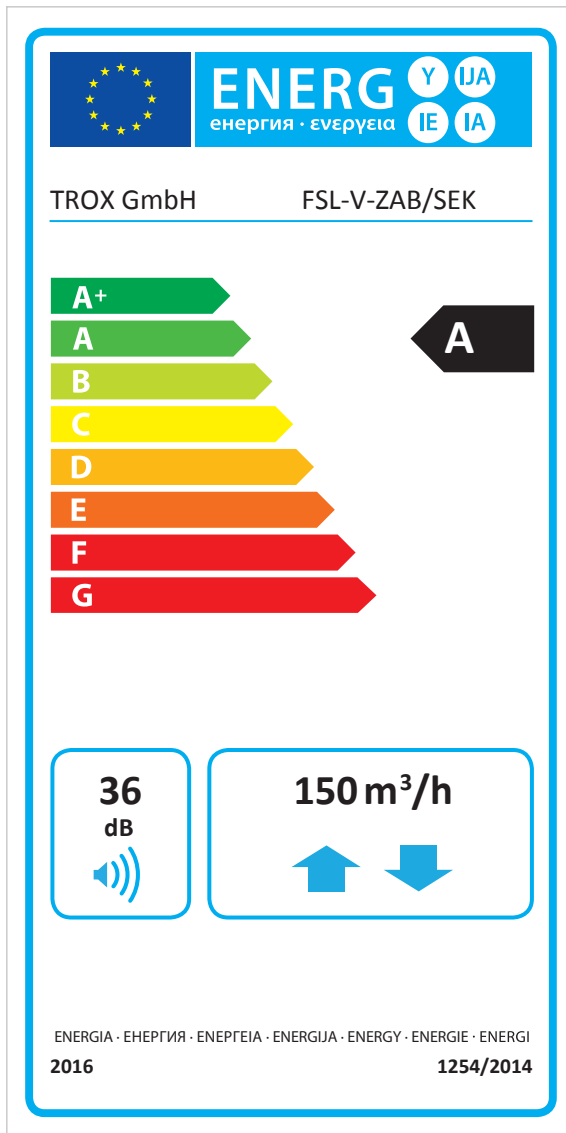

SCHOOLAIR-V

Product information





The art of handling air

a) Manufacturer's name	TROX GmbH Heinrich-Trox-Platz 47504 Neukirchen-Vluyn, Germany	Phone +49 (0)2845 2020 Fax +49 (0)2845 202265 E-mail trox@trox.de Internet www.troxtechnik.com
b) Model identifier	SCHOOLAIR-V-2/KM/397x359x2160/R SCHOOLAIR-V-4/KM/397x359x2160/R SCHOOLAIR-V-2/KO/397x359x2160/R SCHOOLAIR-V-4/KO/397x359x2160/R	

Product information with regard to non-residential ventilation units according to Regulation (EU) No 1253/2014 Article 4 (2)

	Information requirement	Technical data for the supplied product
c)	Type	Non-residential ventilation units
		Bidirectional
d)	Type of drive installed	Variable speed drive (VSD)
e)	Heat recovery system (HRS)	Other (Recuperative)
f)	Thermal efficiency of heat recovery	46 %
g)	Nominal flow rate (\dot{V}_{nom})	0,069 m ³ /s \leftrightarrow 250 m ³ /h
h)	Electric power input at \dot{V}_{nom}	0,045 kW
i)	SFP _{int} at \dot{V}_{nom}	480 W/(m ³ /s)
j)	Face velocity of the filters at \dot{V}_{nom}	0,54 m/s
k)	Nominal external pressure	0 Pa - (Non-ducted unit)
l)	Pressure drop of ventilation components	
	• HR _{SUP} / HR _{ETH}	39 Pa / 45 Pa
	• ODA-filter / ETH-filter	19 Pa / 9 Pa
n)	Static efficiency of fans used in accordance with Regulation (EU) No 327/2011	N.a. - (The fan used is not covered by EU directive 327/2011)
o)	Internal leakage rate at \dot{V}_{nom} and 100 Pa	5,5 %
	External leakage rate at \dot{V}_{nom} and 100 Pa	2,5 %
p)	Annual energy consumption of the outdoor air filter at 3000 h/a	15 kWh/a
q)	Filter warning ①	On the control panel - (LED double blinking)
r)	Sound power level of case-radiated noise, including supply air and extract air terminal units, at \dot{V}_{nom}	41 dB(A)
s)	Disassembly instructions	www.trox.de

 ① Filters have to be changed regularly! This will increase the energy efficiency of the unit, reduce the electricity consumption of the fans and protect our environment in the long term.

SCHOOLAIR-V-1800

Product information



TROX[®] TECHNIK
The art of handling air

a) Manufacturer's name	TROX GmbH Heinrich-Trox-Platz 47504 Neukirchen-Vluyn, Germany	Phone +49 (0)2845 2020 Fax +49 (0)2845 202265 E-mail trox@trox.de Internet www.troxtechnik.com
b) Model identifier	SCHOOLAIR-V-2/KM/604x370x1800/R SCHOOLAIR-V-4/KM/604x370x1800/R SCHOOLAIR-V-2/KO/604x370x1800/R SCHOOLAIR-V-4/KO/604x370x1800/R	

Product information with regard to non-residential ventilation units according to Regulation (EU) No 1253/2014 Article 4 (2)

	Information requirement	Technical data for the supplied product
c)	Type	Non-residential ventilation units
		Bidirectional
d)	Type of drive installed	Variable speed drive (VSD)
e)	Heat recovery system (HRS)	Other (Recuperative)
f)	Thermal efficiency of heat recovery	54 %
g)	Nominal flow rate (\dot{V}_{nom})	0,069 m ³ /s \leftrightarrow 250 m ³ /h
h)	Electric power input at \dot{V}_{nom}	0,042 kW
i)	SFP _{int} at \dot{V}_{nom}	405 W/(m ³ /s)
j)	Face velocity of the filters at \dot{V}_{nom}	0,48 m/s
k)	Nominal external pressure	0 Pa - (Non-ducted unit)
l)	Pressure drop of ventilation components	
	<ul style="list-style-type: none"> • HR_{SUP} / HR_{ETH} • ODA-filter / ETH-filter 	22 Pa / 24 Pa 18 Pa / 16 Pa
n)	Static efficiency of fans used in accordance with Regulation (EU) No 327/2011	N.a. - (The fan used is not covered by EU directive 327/2011)
o)	Internal leakage rate at \dot{V}_{nom} and 100 Pa	13,0 %
	External leakage rate at \dot{V}_{nom} and 100 Pa	7,5 %
p)	Annual energy consumption of the outdoor air filter at 3000 h/a	14 kWh/a
q)	Filter warning ⓘ	On the control panel - (LED double blinking)
r)	Sound power level of case-radiated noise, including supply air and extract air terminal units, at \dot{V}_{nom}	40 dB(A)
s)	Disassembly instructions	www.trox.de



ⓘ Filters have to be changed regularly! This will increase the energy efficiency of the unit, reduce the electricity consumption of the fans and protect our environment in the long term.

SCHOOLAIR-V-HE

Product information



TROX[®] TECHNİK
The art of handling air

a) Manufacturer's name	TROX GmbH Heinrich-Trox-Platz 47504 Neukirchen-Vluyn, Germany	Phone +49 (0)2845 2020 Fax +49 (0)2845 202265 E-mail trox@trox.de Internet www.troxtechnik.com
b) model identifier	SCHOOLAIR-V-HE2/KM/600x2000x408/R SCHOOLAIR-V-HE4/KM/600x2000x408/R SCHOOLAIR-V-HE2/KO/600x2000x408/R SCHOOLAIR-V-HE4/KO/600x2000x408/R	

	Information requirement	Technical data for the supplied product
c)	Type	Non-residential ventilation units
		Bidirectional ventilation unit
d)	Drive type	Speed control
e)	Heat recovery (WRG)	Other (regenerative)
f)	Thermal efficiency of the heat recovery	84 %
g)	Nominal flow rate ($\dot{V}_{pt, nom}$)	0.069 m ³ /s \leftrightarrow 250 m ³ /h
f)	electrical power input at \dot{V}_{nom}	0.04 kW
i)	SVL _{int} at \dot{V}_{nom}	435 W/(m ³ /s)
j)	upstream velocity of the filters at \dot{V}_{Nom}	0.58 m/s
k)	Nominal external pressure	0 Pa - (unit without duct connection)
	pressure loss of the ventilation component	
l)	• WRG _{SUP} / WRG _{ETH}	48 Pa/ 63 Pa
	• ODA-filter / ETH-filter	22 Pa / 18 Pa
n)	Static efficiency of fans in accordance with EU directive 327/2011	n.a. - (The fan used is not covered by EU directive 327/2011)
o)	Internal leakage air ratio at $\dot{V}_{Nominal}$ and 100 Pa	5 %
	External leakage air ratio at $\dot{V}_{Nominal}$ and 100 Pa	5 %
p)	Annual power consumption of the outdoor air filters at 3000 h/year	12 kWh/a
q)	Filter warning ①	On the control panel - (Status LED double blinking)
r)	casing-sound power level incl. supply air and return air on the room end at \dot{V}_{Nom}	43 dB(A)
s)	Information on dismantling	www.trox.de

 ① Filters have to be changed regularly! This will improve the energy efficiency of the unit, reduce the power consumption of the fans and protect our environment in the long term.

SCHOOLAIR-V-HV

Product information



TROX[®] TECHNIK
The art of handling air

a) Manufacturer's name	TROX GmbH Heinrich-Trox-Platz 47504 Neukirchen-Vluyn, Germany	Phone +49 (0)2845 2020 Fax +49 (0)2845 202265 E-mail trox@trox.de Internet www.troxtechnik.com
b) model identifier	SCHOOLAIR-V-HV2/KM/600x2200x408/R SCHOOLAIR-V-HV4/KM/600x2200x408/R SCHOOLAIR-V-HV2/KO/600x2200x408/R SCHOOLAIR-V-HV4/KO/600x2200x408/R	

	Information requirement	Technical data for the supplied product
c)	Type	Non-residential ventilation units
		Bidirectional ventilation unit
d)	Drive type	Speed control
e)	Heat recovery (WRG)	Other (regenerative)
f)	Thermal efficiency of the heat recovery	75 %
g)	Nominal flow rate ($V_{pt, nom}$)	0.111 m ³ /s ⇔ 400 m ³ /h
f)	electrical power input at V_{nom}	0.082 kW
i)	SVL _{int} at \dot{V}_{nom}	350 W/(m ³ /s)
j)	upstream velocity of the filters at \dot{V}_{Nom}	1.05 m/s
k)	Nominal external pressure	0 Pa - (unit without duct connection)
l)	pressure loss of the ventilation component	
	• WRG _{SUP} / WRG _{ETH}	45 Pa/ 51 Pa
	• ODA-filter / ETH-filter	38 Pa / 38 Pa
n)	Static efficiency of fans in accordance with EU directive 327/2011	60 %
o)	Internal leakage air ratio at $\dot{V}_{Nominal}$ and 150 Pa	5 %
	External leakage air ratio at $\dot{V}_{Nominal}$ and 150 Pa	1 %
p)	Annual power consumption of the outdoor air filters at 3000 h/year	20 kWh/a
q)	Filter warning ⓘ	On the control panel - (Status LED double blinking)
r)	casing-sound power level incl. supply air and return air on the room end at \dot{V}_{Nom}	42 dB(A)
s)	Information on dismantling	www.trox.de

 ⓘ Filters have to be changed regularly! This will improve the energy efficiency of the unit, reduce the power consumption of the fans and protect our environment in the long term.

Declaration of hygiene conformity



Declaration of Hygiene Conformity

**Decentralised Ventilation Units
Types SCHOOLAIR-B · SCHOOLAIR-D ·
SCHOOLAIR-V**

Object of the inspection

TROX GmbH, Heinrich-Trox-Platz, D-47504 Neukirchen-Vluyn, Germany, hereby confirm that the decentralised ventilation units of types SCHOOLAIR-B/-D/-V meet the hygiene requirements specified by the standards and regulations listed below.

- European standard
– EN 13779 (09/2007)
- German standards
– VDI 6022, part 1 (07/2011)
– VDI 6035 (09/2009)
- Austrian standards
– ÖNORM H 6021 (09/2003)
- Swiss SWKI regulations
– VA104-01 (04/2006)

For the purpose of this declaration of conformity a sample of each type mentioned above was viewed at the TROX GmbH factory, Heinrich-Trox-Platz, 47504 Neukirchen-Vluyn, Germany, and related data sheets, technical literature, and inspection reports were appraised.

Summary of the test result

The examination of the above-mentioned sample equipment and the appraisal of the available documents have shown that the hygiene requirements specified by the above-mentioned standards and regulations are met.

We hereby confirm that the decentralised ventilation units of types SCHOOLAIR-B/-D/-V meet the hygiene requirements of the specified standards and regulations.

Neukirchen-Vluyn, Germany, 08 November 2011



Dipl.-Ing. Dirk Scherder
trained according to VDI 6022, category A
Product Management

Dipl.-Ing. Jan Heymann
Manager Quality Systems



Certificate

Commissioning report/Maintenance report

Building:	Floor:	Unit:
Commissioning: <input type="checkbox"/>	Maintenance: <input type="checkbox"/>	Date: __ . __ . 20__

Maintenance measures

Item to be checked	Measures	Interval [months]			Done	
		6	12	24	Yes	No
Cleaning the ventilation unit	Remove dust and contamination from the casing and from the air passages inside the unit.		X		<input type="checkbox"/>	<input type="checkbox"/>
Checking air terminal units in the external wall for damage and corrosion (random check)	Clean; if necessary, repair.		X		<input type="checkbox"/>	<input type="checkbox"/>
Checking the heat exchanger, condensate drip tray and condensate drain (random check)	Check for corrosion and hygiene; clean 🔧 37	X ¹	X		<input type="checkbox"/>	<input type="checkbox"/>
Checking outdoor air and exhaust air openings for leakages (random check)	In case of visible leakages: adjust the damper opening angle, replace the actuator, clean		X		<input type="checkbox"/>	<input type="checkbox"/>
	Check if the damper blade closes in case of a power failure			X	<input type="checkbox"/>	<input type="checkbox"/>
Checking filters after any pressure drop, based on hygiene conditions, based on operating time (random checks)	Replace the filter medium, clean the filter chamber, check seals 🔧 36	X ¹	X		<input type="checkbox"/>	<input type="checkbox"/>
Checking the heat recovery unit (random check)	Check seals, adjust or replace if necessary; clean the heat recovery unit; check and clean water drain	X ¹	X		<input type="checkbox"/>	<input type="checkbox"/>
Checking fan functions (random check)	Different fan stages			X	<input type="checkbox"/>	<input type="checkbox"/>
Checking activation of the frost protection function for heat exchangers	Let the supply air temperature sensor cool down to a value below the release temperature and see if the ventilation unit is switched off as a consequence		X		<input type="checkbox"/>	<input type="checkbox"/>
Checking valves for function and leakages (random check)	Check whether the heating and cooling valves open and close correctly and whether the effect of the actuator action is correct			X	<input type="checkbox"/>	<input type="checkbox"/>
Checking the control panel (random check)	Check switching function, setpoint shift			X	<input type="checkbox"/>	<input type="checkbox"/>
Checking control units (random check)	Check circuits, control signals; adjust them if necessary			X	<input type="checkbox"/>	<input type="checkbox"/>

1) if condensation has formed

Comment:	
Next maintenance scheduled for:	
Signature: (Technician)	
Company: (Stamp)	

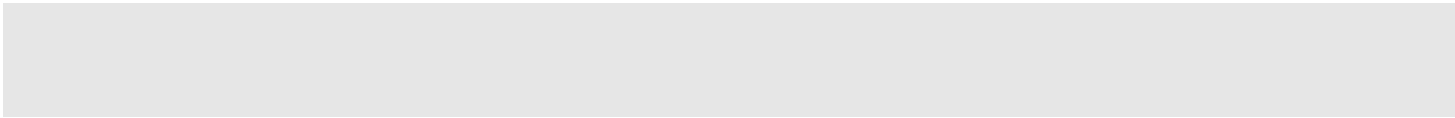



TROX[®] TECHNIK

The art of handling air

TROX GmbH
Heinrich-Trox-Platz
47504 Neukirchen-Vluyn
Germany

Phone: +49 (0) 2845 2020
Fax: +49 (0) 2845 202265
E-mail: trox@trox.de
<http://www.troxtechnik.com>

© TROX GmbH 2017