



Active chilled beams

Type DID632

TROX GmbH

Heinrich-Trox-Platz
47504 Neukirchen-Vluyn
Germany

Phone: +49 (0) 2845 2020

Fax: +49 (0) 2845 202265

E-mail: trox@trox.de

www.troxtechnik.com

Product overview

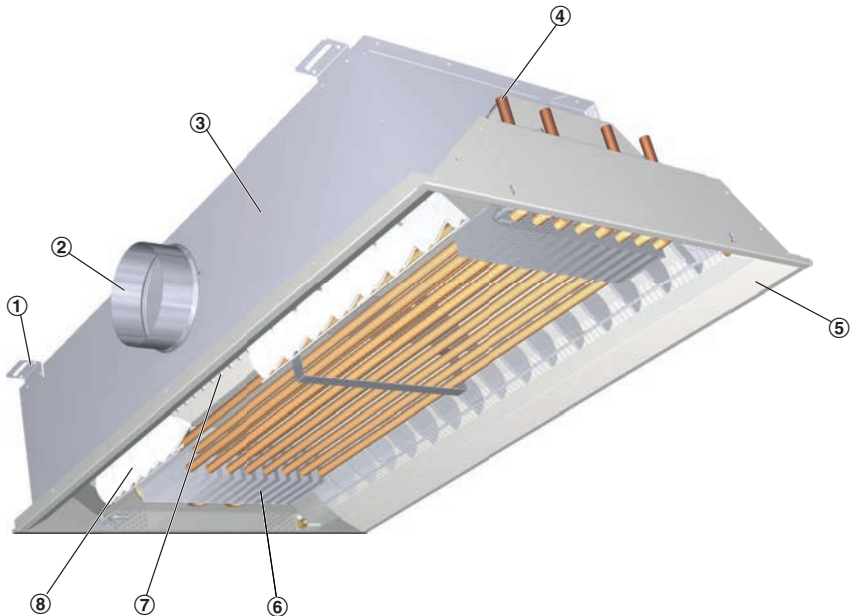

Fig. 1: Schematic illustration of DID632

- | | | | |
|---|--------------------|---|-------------------------------|
| ① | Hanging bracket | ⑤ | Front frame |
| ② | Primary air spigot | ⑥ | Heat exchanger |
| ③ | Casing | ⑦ | Nozzles |
| ④ | Water connections | ⑧ | Air control blades (optional) |

Important notes

Information on the installation manual

This manual enables operating or service personnel to correctly install the product described below and to use it safely and efficiently.

It is essential that these individuals read and fully understand this manual before starting any work. The basic prerequisite for safe working is to comply with the safety notes and all instructions in this manual.

The local regulations for health and safety at work and general safety regulations also apply.

Qualified staff

Specialist personnel

Specialist personnel are individuals who have sufficient professional or technical training, knowledge and actual experience to enable them to carry out their assigned duties, understand any potential hazards related to the work under consideration, and recognise and avoid any risks involved.

Limitation of liability

The information in this manual has been compiled with reference to the applicable standards and guidelines, the state of the art, and our expertise and experience of many years.

The manufacturer does not accept any liability for damages resulting from:

- Non-compliance with this manual
- Incorrect use
- Operation or handling by untrained individuals
- Unauthorised modifications

The actual scope of delivery may differ from the information in this manual for special constructions, additional order options or as a result of recent technical changes.

Personal protective equipment

Personal protective equipment must be worn for all work in order to reduce health or safety hazards to the minimum.

The appropriate protective equipment for a job must be worn for as long as the job takes.

Industrial safety helmet



Industrial safety helmets protect the head from falling objects, suspended loads, and the effects of striking the head against stationary objects.

Protective gloves



Protective gloves protect hands from friction, abrasions, punctures, deep cuts, and direct contact with hot surfaces.

Safety shoes



Safety shoes protect the feet against crushing, falling parts, and slipping on slippery ground.

Correct use

Active chilled beams provide centrally conditioned primary air (fresh air) to the room. Heat exchangers are used for additional cooling and/or heating.

Incorrect use**WARNING!****Danger due to incorrect use!**

Incorrect use of the unit can lead to dangerous situations.

Never use the unit:

- in areas with potentially explosive atmospheres
- in humid rooms
- in rooms with aggressive or dust-laden air

Technical data

Designation	Value
Primary air volume flow rate	6 – 85 l/s, 22 – 306 m³/h
Cooling capacity	Up to 2450 W
Heating capacity	Up to 2970 W
Max. operating pressure, water side	6 bar
Max. operating temperature	75 °C (55 °C when using flexible connecting hoses)
Minimum operating temperature	6 °C

Dimensions

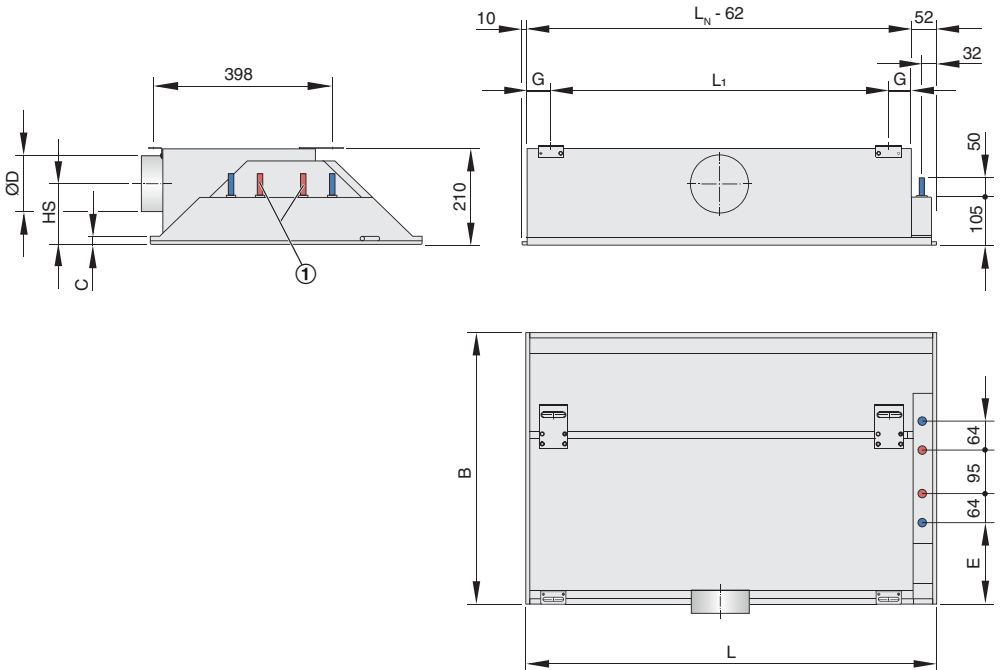

Fig. 2: Dimensional drawing of DID632

Dimensions [mm]		
B	C	E
593	18	177
598	8	179
618	18	189
623	8	192

B = Width of front frame

Dimensions [mm]					
L _N	L	L ₁	ØD	HS	G
900	893 – 1500	735	123	134	51.5
1200	1193 – 1800	1035	123	134	51.5
1500	1493 – 2100	1335	123	134	51.5
1800	1793 – 2400	1035	123	134	351.5
2100	2093 – 2700	1315	158	116	361.5
2400	2393 – 3000	1435	158	116	451.5
2700	2693 – 3000	1515	158	116	561.5
3000	2993 – 3000	1635	158	116	651.5

L_N = Nominal length

L = Total length (diffuser face)

Weight [kg]								
Variant	L _N [mm]							
	900	1200	1500	1800	2100	2400	2700	3000
DID632-LR	18	22	27	32	39	47	54	61
DID632-LQ	17	21	26	31	38	46	53	60
DID632-GL	20	25	31	36	43	52	59	67
DID632-GQ	20	25	31	36	43	52	59	67
Contained water (max.)	1.8	2.4	3	3.6	4.2	4.8	5.4	6

Transport and storage

Transport

CAUTION!

Danger of injury from sharp edges, sharp corners and thin sheet metal parts!

Sharp edges, sharp corners and thin sheet metal parts may cause cuts or grazes.

- Be careful when carrying out any work.
- Wear protective gloves, safety shoes and a hard hat.

NOTICE!

Carry the unit in pairs in order to prevent any damage.

Storage

Please note:

- Store the unit only in its original packaging
- Protect the unit from the effects of weather
- Protect the unit from humidity, dust and contamination
- Storage temperature: -10 to 50 °C
- Relative humidity: 95 % max., non-condensing

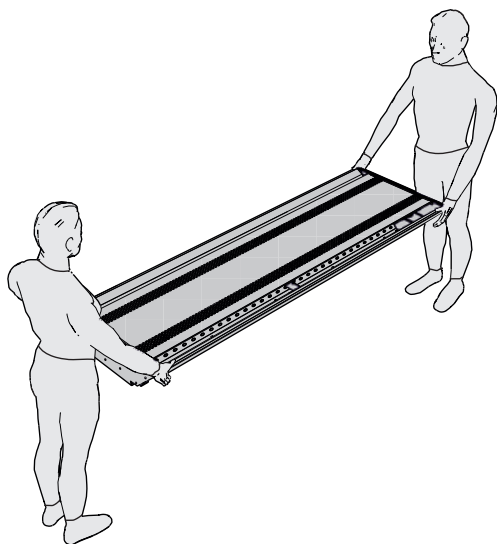

Fig. 3: Carrying the unit in pairs

Use only lifting and transport gear designed for the required load. Always secure the load against tipping and falling.

Upon delivery, carefully remove the packaging and check the unit for transport damage and completeness.

Ceiling installation

Ceiling systems

Active chilled beams are typically installed in suspended ceilings. Installation in the most common ceiling systems is shown below.

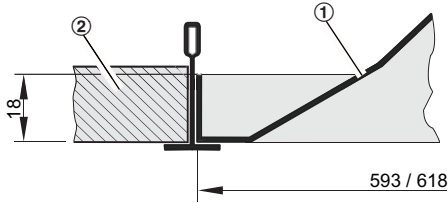

Fig. 4: Ceiling installation, visible T-bars

- ① DID632
- ② Ceiling tile

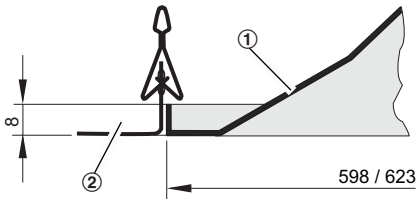

Fig. 5: Ceiling installation with clamping profile

- ① DID632
- ② Ceiling tile

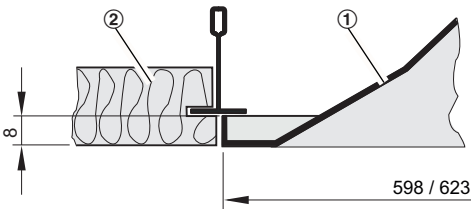

Fig. 6: Ceiling installation, concealed T-bars

- ① DID632
- ② Ceiling tile

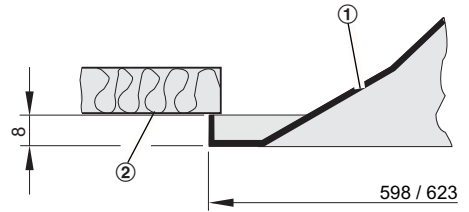

Fig. 7: Ceiling installation, plasterboard ceiling

- ① DID632
- ② Plasterboard ceiling

Installing the unit

Personnel:

- Specialist personnel

Protective equipment:

- Industrial safety helmet
- Safety shoes
- Protective gloves

If possible, install the unit before fixing the ceiling tiles; if this is not possible, remove the adjacent ceiling tiles.

Only work in pairs; preferably use a lift.



DANGER!

Danger of death from the fall of suspended loads!

- Only use fixing materials designed for the required load.
- Use all hanging brackets supplied.
- Stand clear of suspended loads, unless properly secured.
- Check secure fixing after installation.

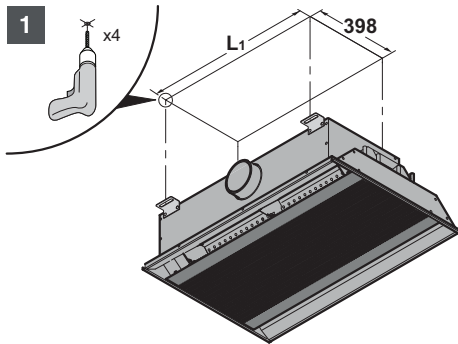
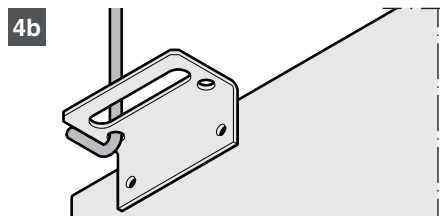
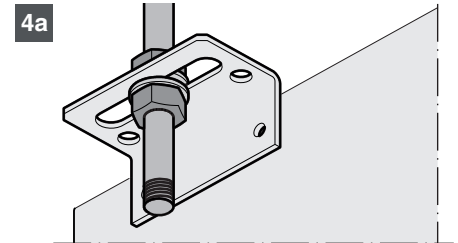
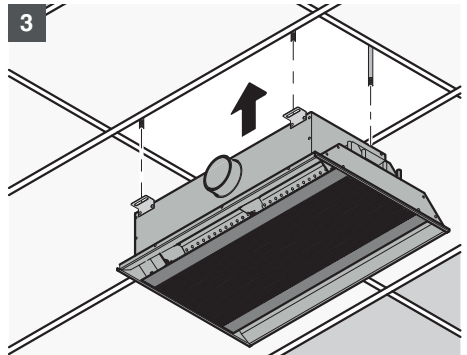
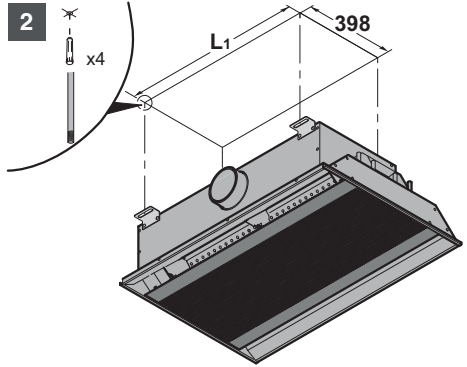

Connecting the water pipes

CAUTION!

Hot surface!

Danger of burn or scald injuries when working on the hot water system.

Before working on the water-side connections, shut down the system, depressurise it and let it cool down.

The heat exchanger is fitted with water flow and water return connections:

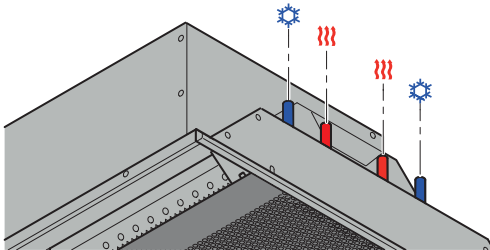

Fig. 8: DID632 with 4-pipe system

- 2-pipe system: 2 water connections
- 4-pipe system: 4 water connections

Make sure that the water temperature does not fall below the dew point.

Water connection	Spanner	Type of connection
Copper tubes 12 × 1 mm	–	Soldered (rigid)
		Flexible hoses (accessory)
G 1/2" external thread and flat seal	SW21	Screw connection (rigid)
		Flexible hoses (accessory)
G 1/2" union nut and flat seal	SW24	Screw connection (rigid)
		Flexible hoses (accessory)

Connecting the unit – screw connection

Personnel:

- Specialist personnel

Protective equipment:

- Industrial safety helmet
- Safety shoes
- Protective gloves

Ensure that the surfaces are clean

1. ▶ Insert seal and tighten screw connection by hand.

NOTICE!

Incorrect assembly will damage the heat exchanger!

Always use a suitable tool to counter the tightening force in order to prevent any damage.

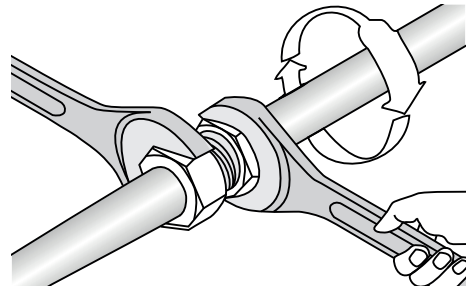

2. ▶ Tighten screw connections with a spanner.

NOTICE!

Subzero temperatures will damage the heat exchanger!

Only fill the heat exchanger if there is no danger of freezing.

3. ▶ Fill the heat exchanger and vent it. To fill the system, use clean tap water (pH value 6.5 to 9) or a water glycol mixture (max. 30% glycol).

4. ▶ Check the system for leaks immediately after installation and then in regular intervals.

Connecting the ductwork

Active chilled beams are fitted with a primary air (fresh air) connection. An extract air connection is optional.

Spigots are suitable for circular ducts to EN 1506 or EN 13180.

The optional extract air spigot (diameter 123 mm) is fitted to one end of the active chilled beam at a 45° angle. The extract air spigot may be on the same side as the primary air spigot or on the opposite side.

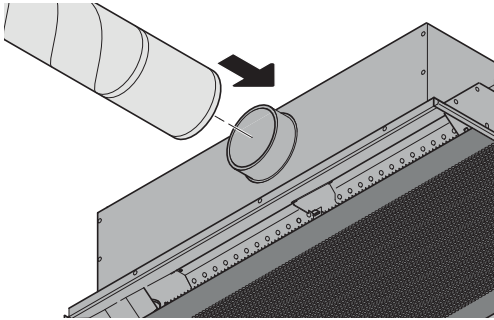

Commissioning

Before you start commissioning:

- Check active chilled beams for correct position
- Remove protective films, if any
- Ensure that all connections are correct
- Ensure that all active chilled beams are clean and free from residues and foreign matter
- Ensure that the water system including the heat exchanger has been filled and vented

Setting the air control blades

The air discharge pattern can be changed by adjusting the optional air control blades in 15° increments up to 45° to the left or right.

Three different air patterns can be set.

! NOTICE!

Incorrect handling will damage the air control blades!

To avoid any damage, always use both hands to move the air control blades.

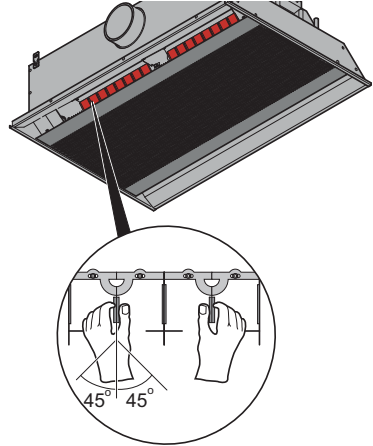

Fig. 9: Changing the air discharge pattern

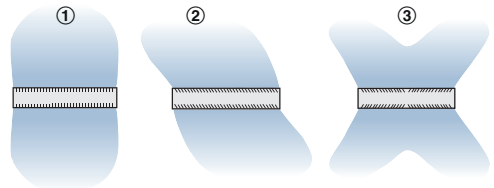

Fig. 10: Examples

- ① Straight air discharge
- ② Angled air discharge
- ③ Divergent air discharge

Cleaning

Cleaning the casing

The casing may be cleaned with a damp cloth. Sticky dirt or contamination may be removed with a commercial, non-aggressive cleaning agent. Cleaning agents that contain chlorine must not be used.

Cleaning the heat exchanger

Personnel:

- Specialist personnel

Protective equipment:

- Industrial safety helmet
- Safety shoes
- Protective gloves

CAUTION!

Hot surface!

Danger of burn injuries when working on the hot water system.

Before working on the water-side connections, shut down the system and let it cool down.

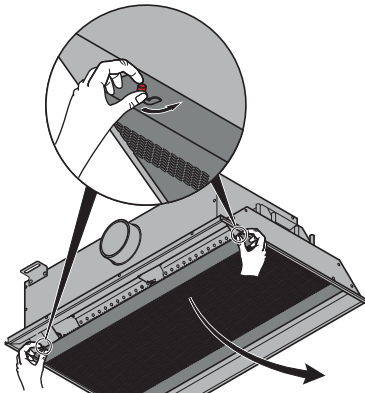

Fig. 11: Opening the induced air grille

1. ▶ To open the induced air grille, release the interlock and swivel the grille downwards. To completely remove the grille, loosen the bolts with an SW3 Allen key.

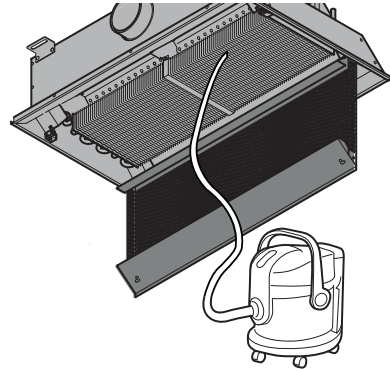

Fig. 12: Cleaning the heat exchanger

2. ▶ Carefully clean the heat exchanger with an industrial vacuum cleaner. Be careful to not damage the fins. We recommend using a soft brush on the suction inlet.

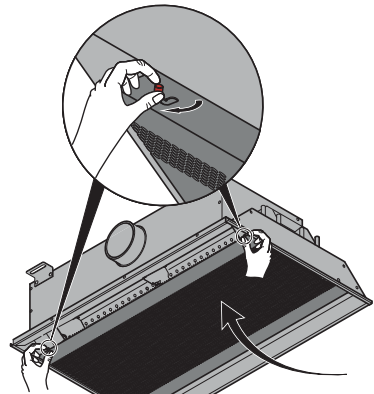

Fig. 13: Closing the induced air grille

3. ▶ After cleaning, screw-fix and close the grille.

CAUTION!

Danger of head injuries from the fall of the induced air grille!

Check that the induced air grille is securely fixed.

