

Attachments

Attachments for doors

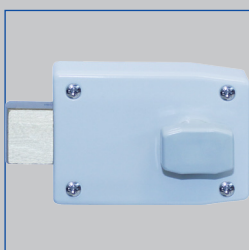

Removable front locking lever (of double lever locking device)



Cylinder rim lock



Pressure relief valve



Inspection window



For the improvement and extension of the range of applications

Attachments for low-leakage steel doors and inspection access doors to meet demanding requirements and extend the range of applications

- Cylinder rim lock to lock the door using either a rotary knob or a key
- Mortice lock, ready to accommodate a profile cylinder, to lock the door
- Double skin inspection window
- Pressure relief valve for pressure equalisation between the rooms on either side of the door; allows the door to be opened without much effort
- Double lever locking device with removable front locking lever; without the front lever the door cannot be opened from the outside
- Any combination of attachments for steel doors

Type		Page
Z* – Doors	General information	Z* – 2
	Function	Z* – 3
	Variants	Z* – 5
	Product details	Z* – 7

Application

Application

– For the improvement and extension of the

range of applications of low-leakage steel doors and inspection access doors

Arrangement of attachments for single leaf low-leakage steel door of Type ST

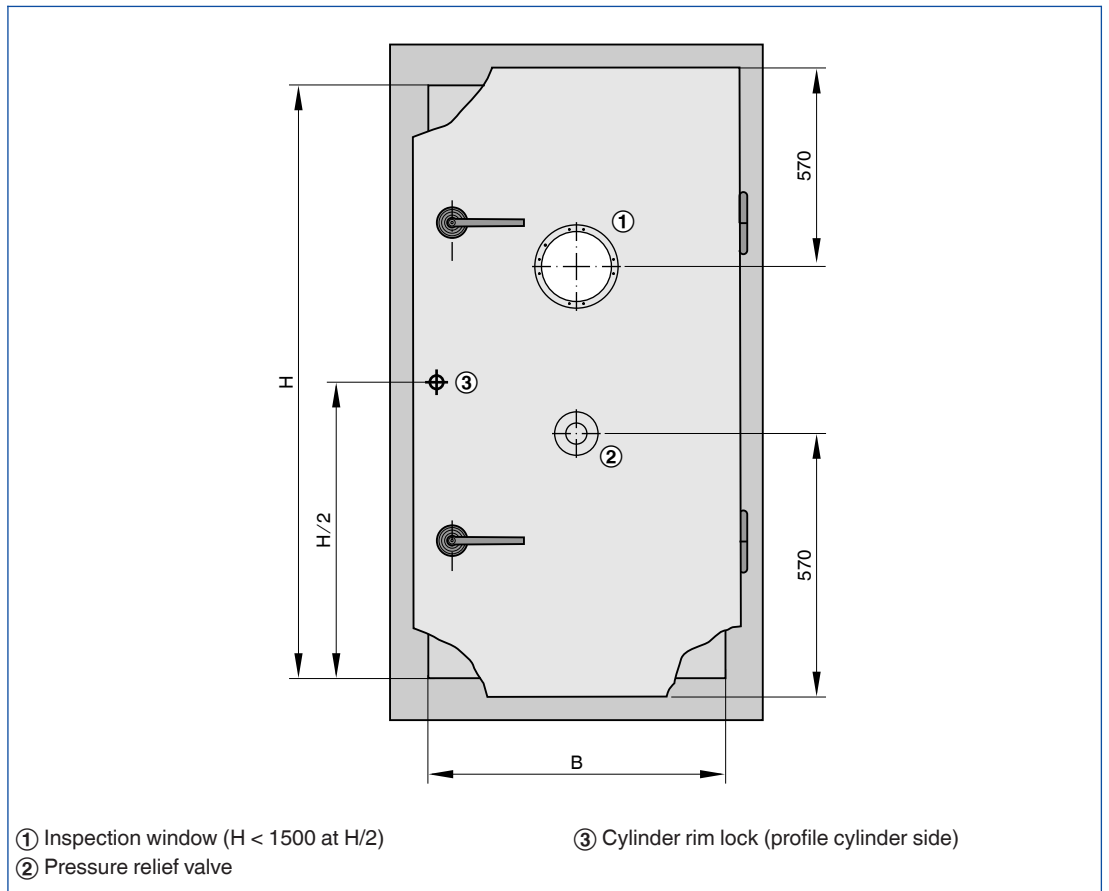

Right hinge

Arrangement of attachments for double leaf low-leakage steel door, variant ST-D

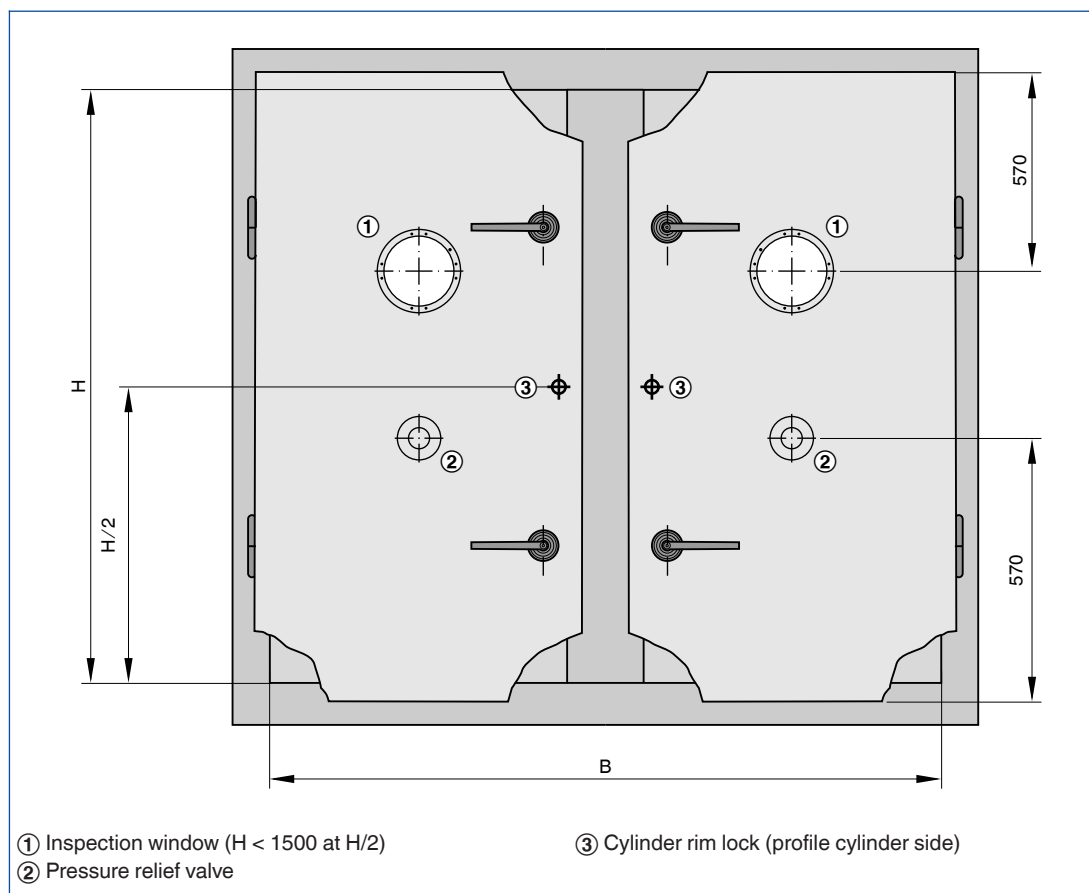

Arrangement of attachments for low-leakage inspection access doors of Type BS

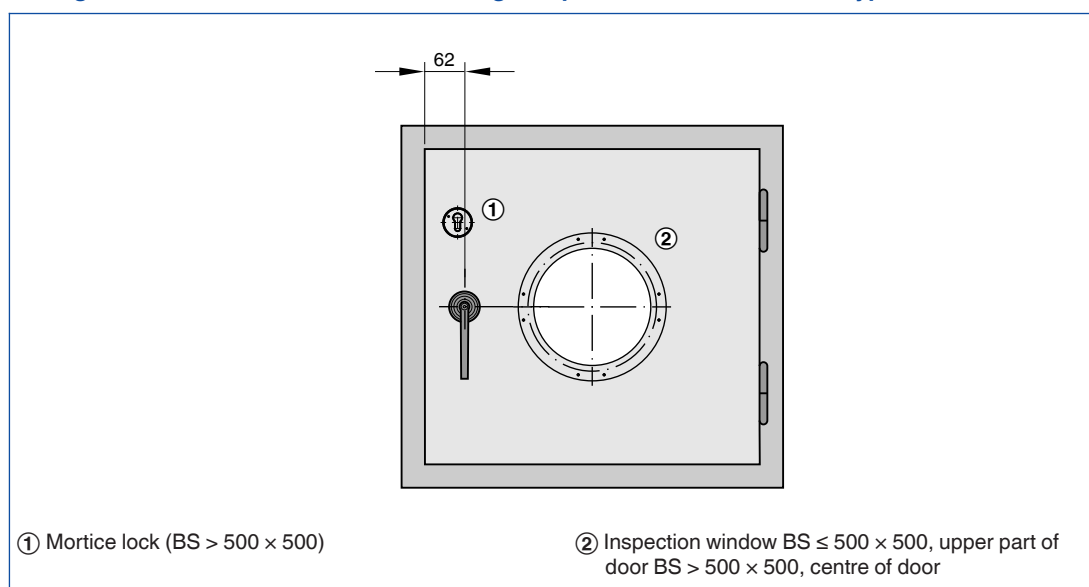

Right hinge

Cylinder rim lock



Cylinder rim lock



Inspection window

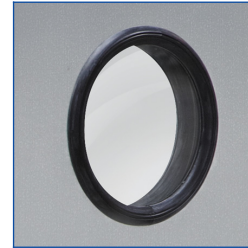

Pressure relief valve



Removable front locking lever (of double lever locking device)



Any attachments are to be defined with the order code of low-leakage doors.

Z01

Application

- Used to lock the door and to manually open it from the inside

Parts and characteristics

- BKS rim lock
- BKS cylinder with three keys
- For double leaf doors: two identical cylinders

Z02

Application

- Used to lock the door, ready to accommodate a profile cylinder

- Mortice lock for profile cylinders (profil cylinder by others), 22 mm inside length, 35 mm outside length
- Profile cylinder, e.g. BKS no. 3100
- Two escutcheons

Parts and characteristics

Z03

Application

- For the improvement and extension of the range of applications of low-leakage steel

doors and inspection access doors

Parts and characteristics

- Double skin inspection window
- Fixed with clamping profiles

Z04

Application

- Used for manual equalisation between the rooms on either side of the door; allows the door to be opened without much effort

Parts and characteristics

- Pressure relief valve made of aluminium diecast
- Perimeter foam rubber seals on both sides
- Two star grips

Z05

Application

- Without the front lever the door cannot be

opened from the outside

front locking lever

Parts and characteristics

– Double lever locking device with removable

- Front locking lever made of aluminium diecast
- Fits square shafts

Attachments for low-leakage doors

Order code detail	Cylinder rim lock	Mortice lock	Inspection window	Pressure relief valve	Removable front locking lever
	Z01	Z02	Z03	Z04	Z05
Z01	x				
Z02		x			
Z03			x		
Z04				x	
Z05					x
Z06	x		x		
Z07		x	x		
Z08			x	x	
Z09			x		x
Z10	x			x	
Z11		x		x	
Z12				x	x
Z13	x				x
Z14		x			x
Z15	x		x	x	
Z16		x	x	x	
Z17			x	x	x
Z18	x		x		x
Z19		x	x		x
Z20	x			x	x
Z21		x		x	x
Z22	x		x	x	x
Z23		x	x	x	x

Combinations with Z03 and Z04 from H=1500 mm

Attachments for low-leakage inspection access doors

Order code detail	Cylinder rim lock	Mortice lock	Inspection window	Removable front locking lever
	Z01	Z02	Z03	Z05
Z01	x			
Z02		x		
Z03			x	
Z05				x

BS ≤ 400 × 400 only with Z05

BS > 500 × 500

BS ≤ 500 × 500 upper part of door

B > 500 × 500 centre of door

Cylinder rim lock (interior lever)

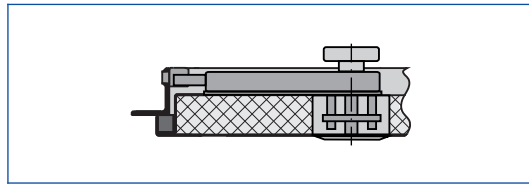

Can also be installed on the opening side

Mortice lock

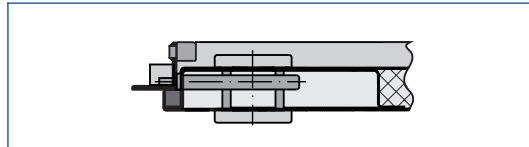

Only from BS > 500 × 500 mm, installation above the lever

Inspection window

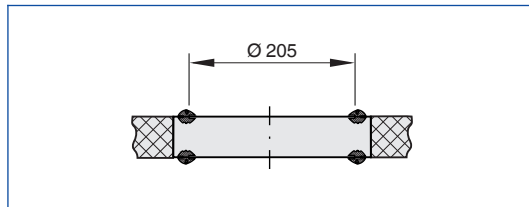

BS < 500 × 500 mm: upper part of door, BS ≥ 500 × 500 mm: centre of door

Pressure relief valve

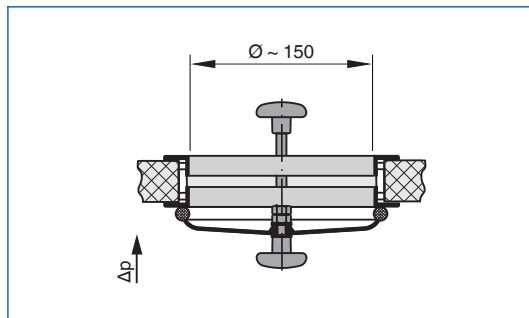

Not available for BS

Removable front locking lever (of double lever locking device)

